

Cartridge cavity

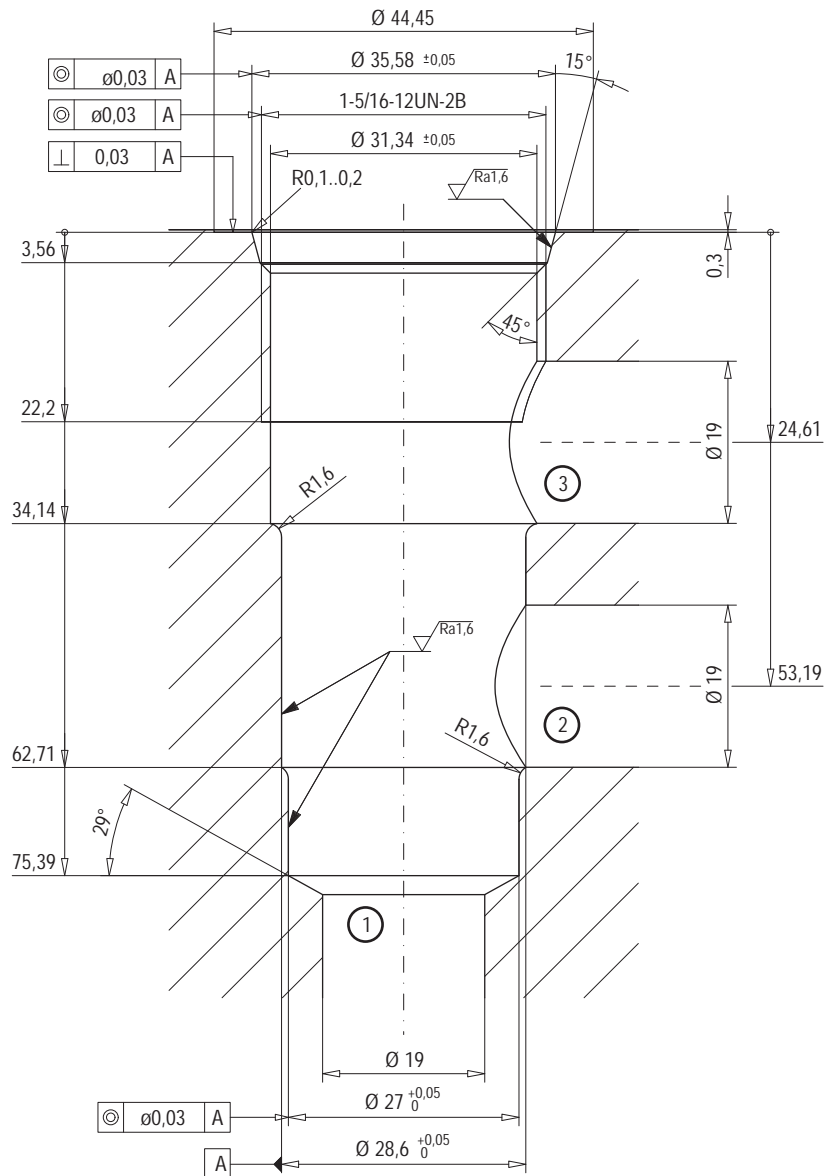

3-way-cavity

(Drawing no. 1-1364.4)

Application

Cartridge type:
QDPPU16-...

Data sheet number:
2.6-670

Cartridge type:

Data sheet number: