

Cartridge cavity ISO 7789-33-02-0-98

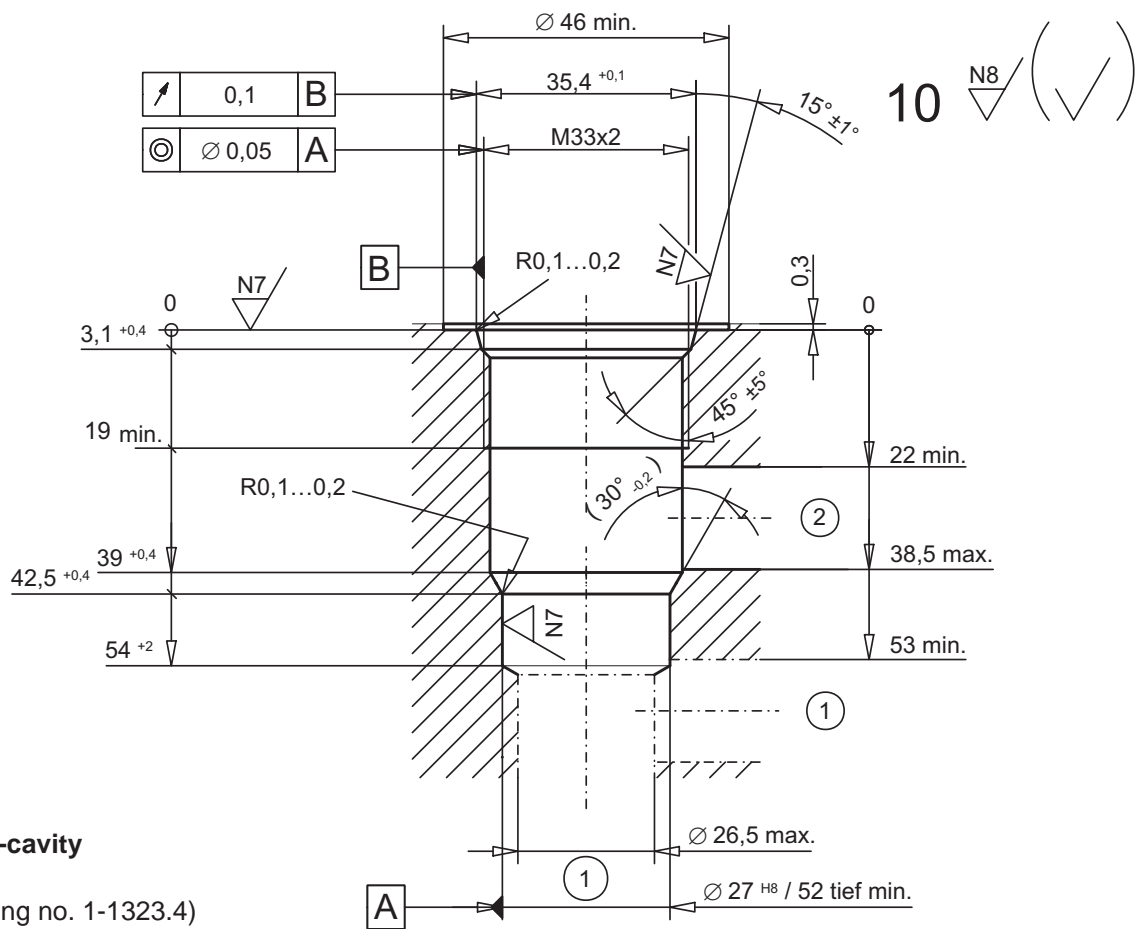

3-way-cavity

(Drawing no. 1-1323.4)

Cavity tools

Denomination:

Form drill
Form reamer
Tap

Article number:

983.0107
983.0207
983.0602

Form tool set

consisting of; form drill, form reamer and tap

983.0807

Application

Cartridge type:

BVPPM33-...
BVVPM33-...

Data sheet number:

2.3-550/551
2.3-552

Cartridge type:

Data sheet number: