

Cavity for poppet valve cartridge NG10

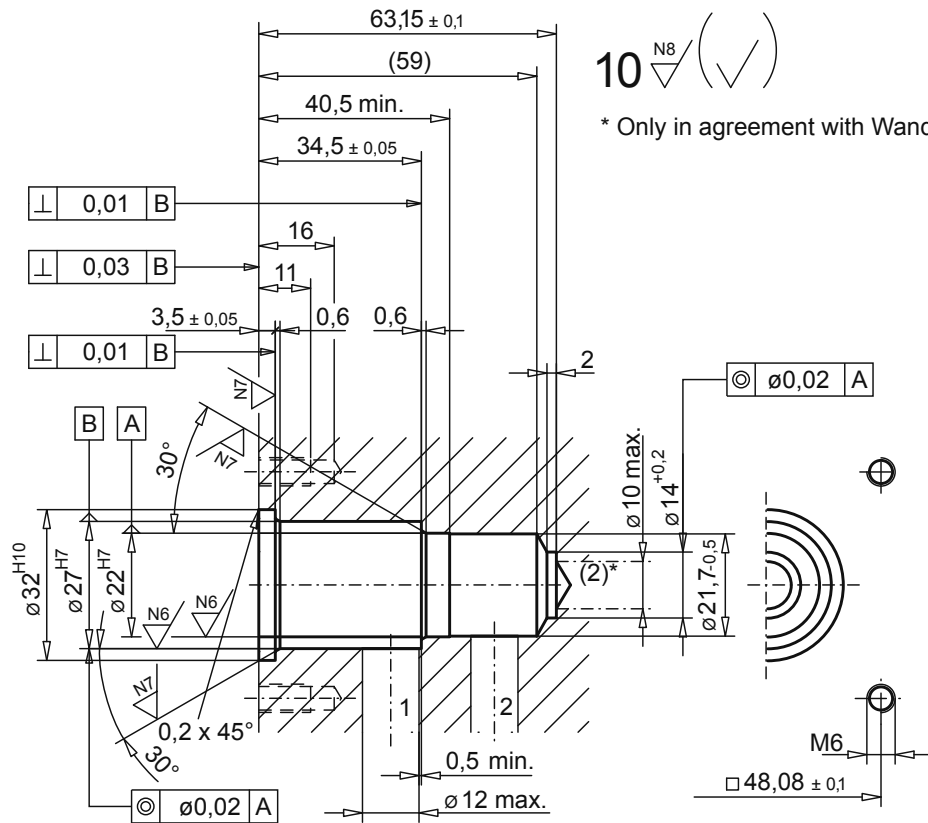

10 N8 (✓) (✓)

* Only in agreement with Wandfluh AG!

2-way poppet valve cavity closed when deenergised

(Drawing no. 1-1039.4)

Cavity tools

Denomination:

Form drill
Form reamer

Article number:

983.2103
983.2203

Form tool set

consisting of; form drill and form reamer

983.2803

Application

Cartridge type:

.2210-...

Data sheet number:

1.11-2040

Cartridge type:

Data sheet number: