

**Cavity for poppet valve cartridge NG6**

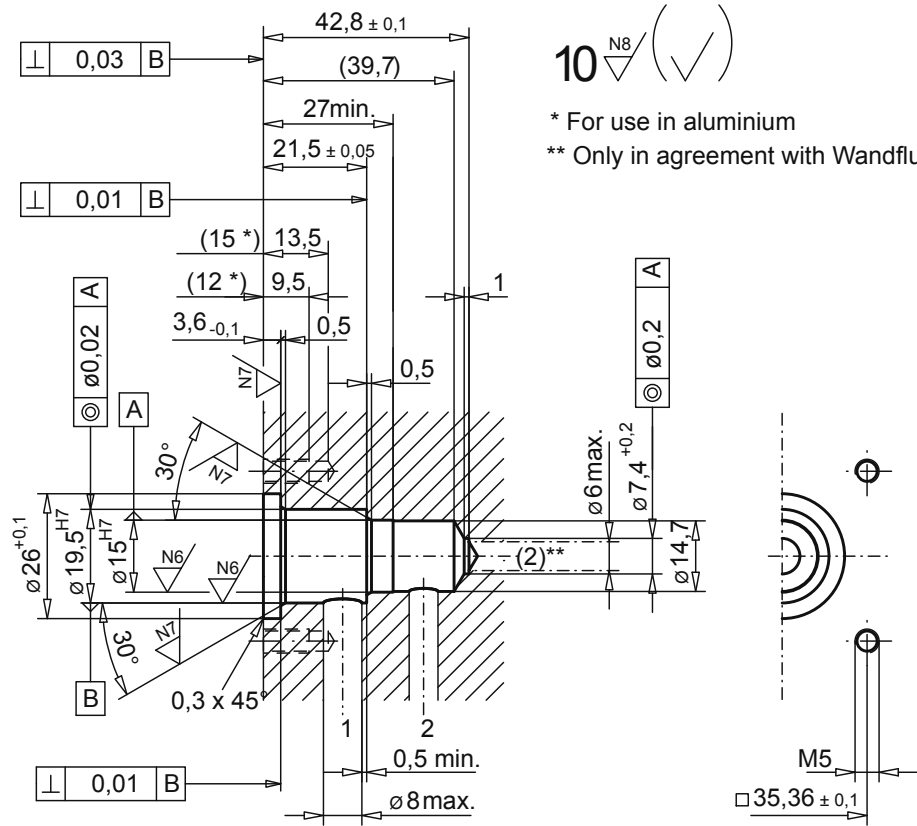

10<sub>N8</sub> (√)  
\* For use in aluminium  
\*\* Only in agreement with Wandfluh AG!

**2-way poppet valve cavity  
closed when deenergised**

(Drawing no. 1-852.4)

**Cavity tools**

<b>Denomination:</b>	<b>Article number:</b>
Form drill	983.2102
Form reamer	983.2202
<b>Form tool set</b>	983.2802
consisting of; form drill and form reamer	

**Application**

<b>Cartridge type:</b>	<b>Data sheet number:</b>	<b>Cartridge type:</b>	<b>Data sheet number:</b>
.2206-...	1.11-2030		