

**Cavity for poppet valve cartridge NG4**

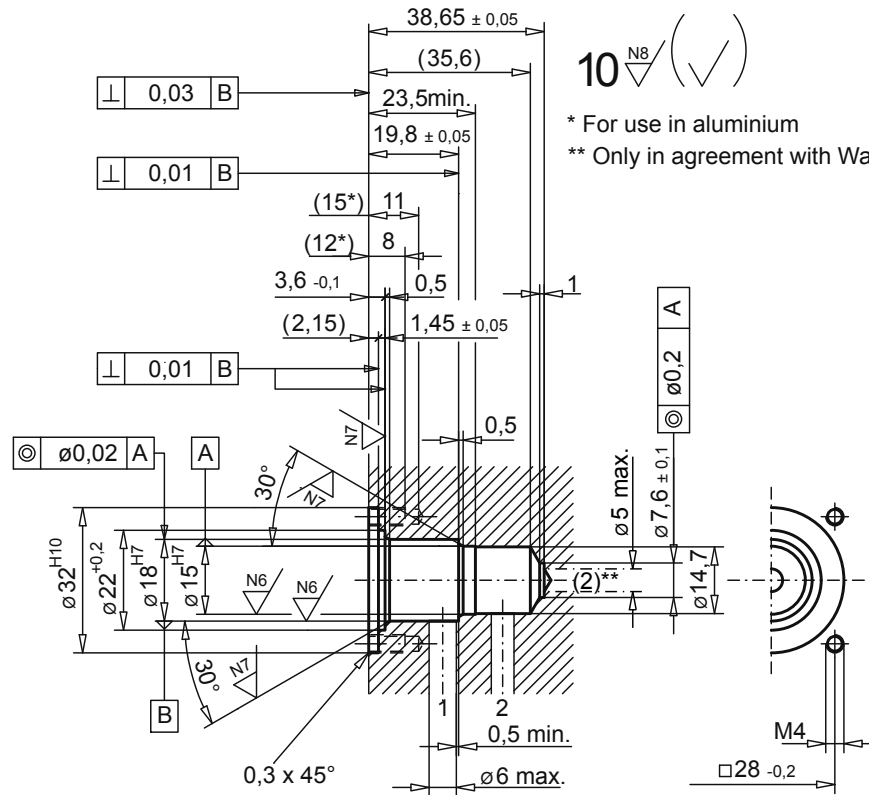

**2-way poppet valve cavity  
closed when deenergised**

(Drawing no. 1-1058.4)

**Cavity tools**

**Denomination:**

Form drill  
Form reamer

**Article number:**

983.2100  
983.2200

**Form tool set**

consisting of; form drill and form reamer

983.2807

**Application**

**Cartridge type:**

.2204-...

**Data sheet number:**

1.11-2020

**Cartridge type:**

**Data sheet number:**