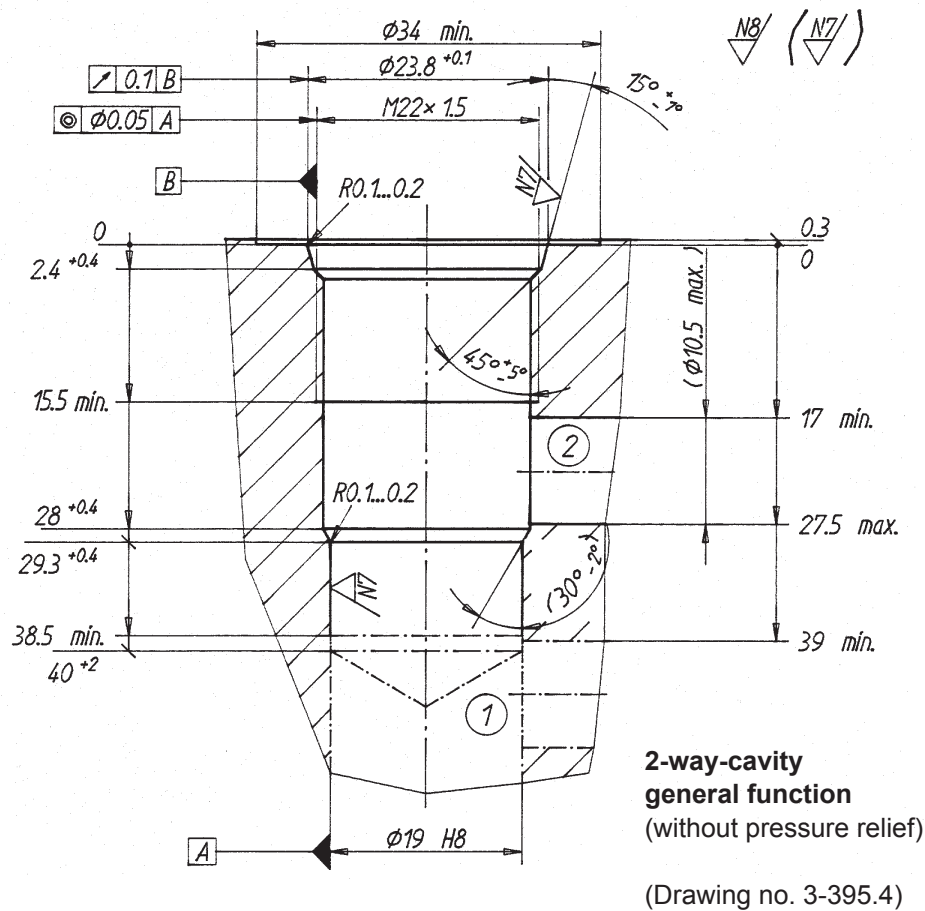

Cartridge cavity ISO 7789-22-01-0-98

Cavity tools
Denomination:

 Form drill
 Form reamer
 Tap

Article number:

 983.0104
 983.0204
 983.0601

Form tool set

consisting of; form drill, form reamer and tap

983.0804

Application
Cartridge type:

SDSPM22-BA / AB...	1.11-2060
SDXPM22-BA/AB...	1.11-2062
SDYPM22-BA/AB...	1.11-2063/2064
SVSPM22-...	1.11-2065
SVXPM22-...	1.11-2067
SVYPM22-...	1.11-2068/2069
SVSPM22-BC/CB...	1.11-2082
D.PPM22-...	2.6-530/531

Data sheet number:
Cartridge type:

D.VPM22-...	2.6-540
QRSPM22	2.5-530
QZ.PM22	2.5-535
QNPPM22	2.6-630/631
QNVPM22	2.6-632

Data sheet number: