

Cartridge cavity ISO 7789-22-06-0-98

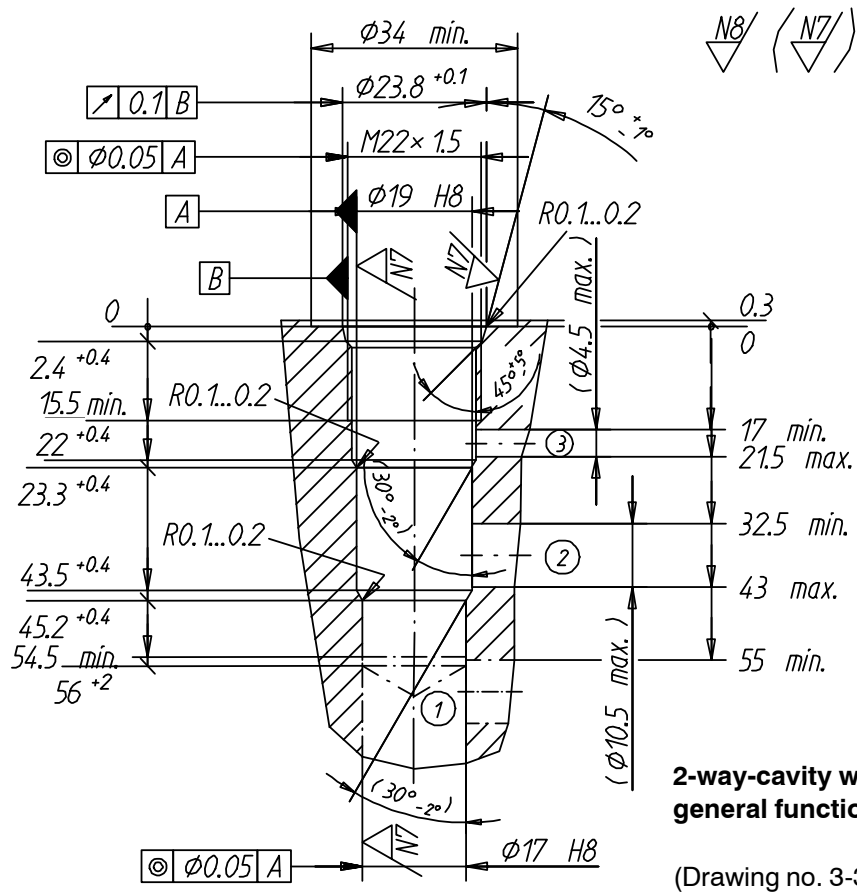

Cavity tools

Denomination:

Form drill
Form reamer
Tap

Article number:

983.0101
983.0201
983.0601

Form tool set

consisting of; form drill, form reamer and tap

983.0801

Application

Cartridge type:

FV.PM22-...
US.PM22-...
U.FPM22-...

Data sheet number:

2.1-546
2.1-548
2.5-630

Cartridge type:

Data sheet number: