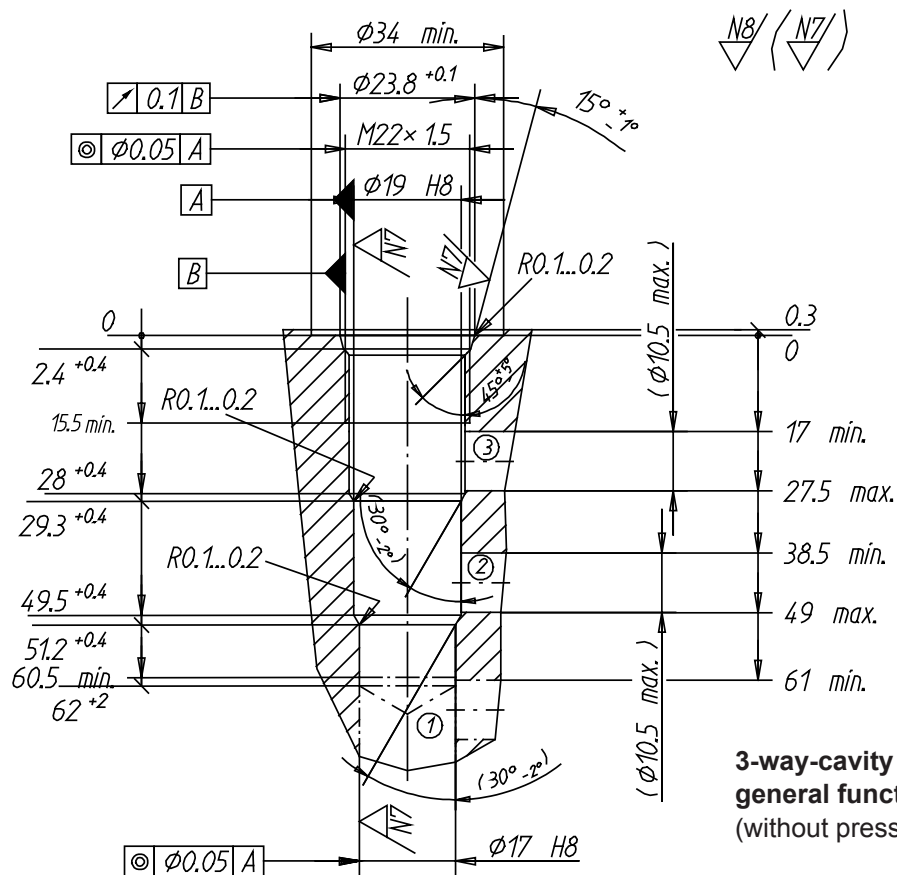

Cartridge cavity ISO 7789-22-04-0-98

3-way-cavity
general function
 (without pressure relief)

(Drawing no. 2-633.4)

Cavity tools
Denomination:

Form drill
 Form reamer
 Tap

Article number:

983.0102
 983.0202
 983.0601

Form tool set

consisting of; form drill, form reamer and tap

983.0802

Application
Cartridge type:
Data sheet number:

SDSPM22-FG...	1.11-2060
SDXPM22-FG	1.11-2062
SDYPM22-FG	1.11-2063/2064
MV.PM22-...	2.2-530
MVEPM22-...	2.2-536
MVPPM22-...	2.3-630/629
MVVPM22-...	2.3-631
MVCPM22-...	2.3-634

Cartridge type:
Data sheet number:

MQPPM22-...	2.3-640/641
MQVPM22-...	2.3-642
QD.PM22	2.5-540
QDPPM22-...	2.6-645/644
QDVPM22-...	2.6-646