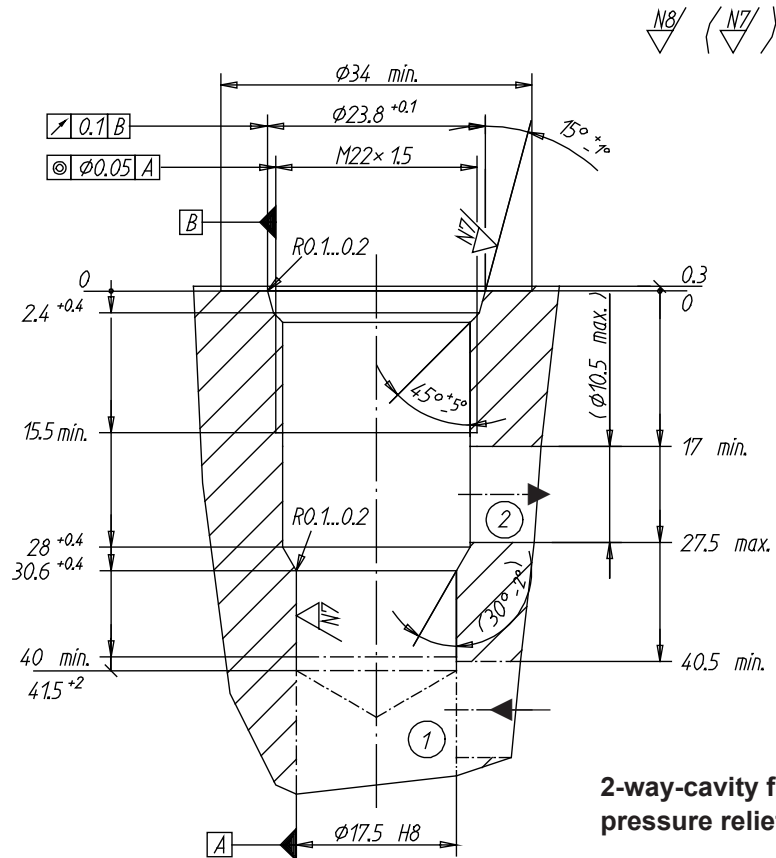

Cartridge cavity ISO 7789-22-02-0-98

**2-way-cavity for
pressure relief**

(Drawing no. 2-632.4)

Cavity tools
Denomination:

Form drill
Form reamer
Tap

Article number:

983.4101
983.4201
983.0601

Form tool set

consisting of; form drill, form reamer and tap

983.4801

Application
Cartridge type:

BV.PM22-...
BVTPM22-...
BVEPM22-...
BA.PM22-...
BK.PM22-...
BVPPM22-...
BVVPM22-...
BVIPM22-...

Data sheet number:

2.1-530
2.1-532
2.1-536
2.1-540
2.1-542
2.3-530/529
2.3-531
2.3-532

Cartridge type:

BVCPM22-...
BVBPM22-...
BDPPM22-...
BDVPM22-...
BDIPM22-...
BDWPM22-...
BDCPM22-...
BDBPM22-...

Data sheet number:

2.3-534
2.3-535
2.3-540/539
2.3-541
2.3-542
2.3-543
2.3-544
2.3-545/546