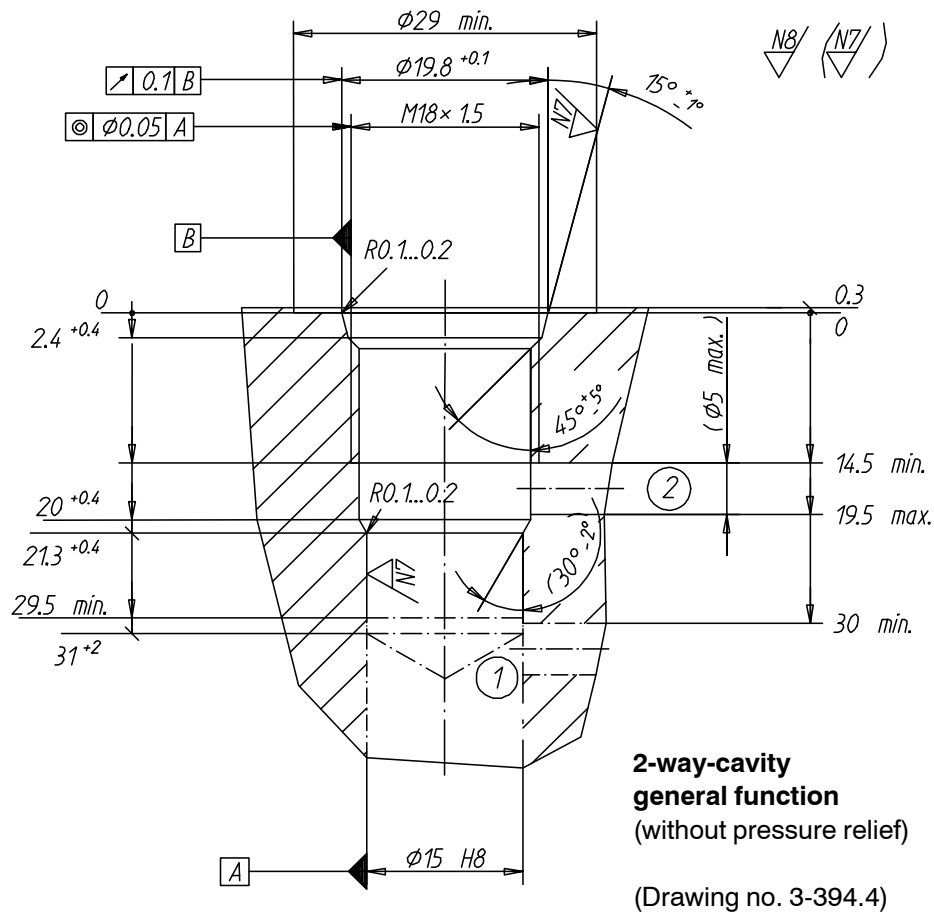

Cartridge cavity ISO 7789-18-01-0-98

Cavity tools
Denomination:

 Form drill
 Form reamer
 Tap

Article number:

 983.0100
 983.0200
 983.0600

Form tool set

consisting of; form drill, form reamer and tap

983.0800

Application
Cartridge type:

 SDSPM18-BA / AB...
 SVSPM18-BC/CB...
 DN.PM18-...
 DR.PM18-...
 QA.PM18-...
 D.PPM18-...

Data sheet number:

 1.11-2050
 1.11-2080
 2.4-510
 2.4-610
 2.5-510
 2.6-510

Cartridge type:
Data sheet number: