

Cartridge cavity ISO 7789-18-02-0-98

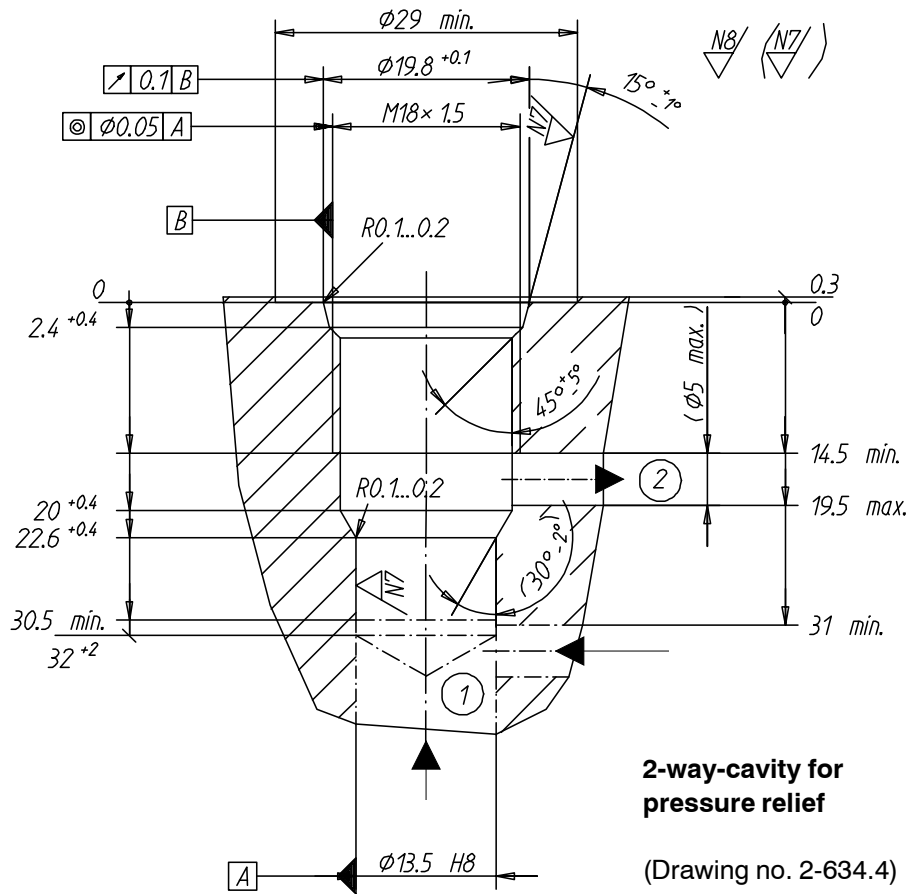

Cavity tools

Denomination:

Form drill
Form reamer
Tap

Article number:

983.4100
983.4200
983.0600

Form tool set

consisting of; form drill, form reamer and tap

983.4800

Application

Cartridge type:

BV.PM18-...
BS.PM18-...
BVPPM18-...
BDPPM18-...

Data sheet number:

2.1-510
2.1-520
2.3-510
2.3-520

Cartridge type:

Data sheet number: