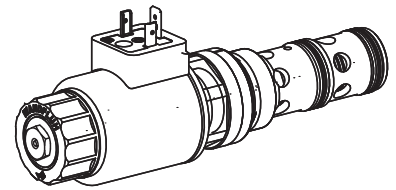

**Proportional 3-way flow control valve  
Screw-in cartridge**

- Direct operated, pressure compensated
- $Q_{\max} = 100 \text{ l/min}$ ,  $p_{\max} = 350 \text{ bar}$
- $Q_{N\max} = 63 \text{ l/min}$

**1<sup>5</sup>/<sub>16</sub>"-12 UN**  
Wandfluh standard

**DESCRIPTION**

Direct operated, pressure compensated proportional flow control valve as a screw-in cartridge with a thread 1<sup>5</sup>/<sub>16</sub>"-12 UN for cavity acc. to Wandfluh standard. Two flow ranges are available. The volume flow is adjusted by a Wandfluh proportional solenoid (VDE standard 0580). The cartridge body is made of steel. A special surface treatment guarantees a good protection against corrosion and wear as well as very good low-friction characteristics of the pressure compensating- and throttle spool. The solenoid coil is zinc-/nickel-coated.

**FUNCTION**

The 3-way flow control valve serves for maintaining the speed of a consumer constant independent of the load. Superfluous pump output flow is fed into the return flow system in a cost saving manner, and as a result, prevents an overheating of the hydraulic system. The power controlled, proportional solenoid running in oil acts directly on the throttle spool, which opens the throttle segments in the cartridge body. Proportional to the current demand of the proportional solenoid, the throttle aperture changes, and with this the volume flow. In case of a current-free solenoid, the throttle spool is held in closed position by a spring. For driving the valve, Wandfluh proportional amplifiers are available (see Register 1.13).

**APPLICATION**

Proportional flow control valves are suitable for feed control systems, where the consumer flow has to be maintained constant with a changing load. The screw-in cartridge is suitable for installation in control blocs.

**TYPE CODE**

		Q D P PU16 - <input type="checkbox"/> - <input type="checkbox"/> / <input type="checkbox"/> <input type="checkbox"/> - <input type="checkbox"/> <input type="checkbox"/> # <input type="checkbox"/>	
Flow control valve			
3-way construction			
Proportional			
Screw-in cartridge 1 <sup>5</sup> / <sub>16</sub> "-12 UN			
Nominal volume flow rates $Q_N$	32 l/min <input type="checkbox"/> 32		
	63 l/min <input type="checkbox"/> 63		
Standard nominal voltage $U_N$	12 VDC <input type="checkbox"/> G12		
	24 VDC <input type="checkbox"/> G24		
	without solenoid coil <input type="checkbox"/> X5		
Slip-on coil	Metal housing, round <input type="checkbox"/> W		
	Metal housing, square <input type="checkbox"/> M*		
Electric connection	Connector socket EN 175301-803 / ISO 4400 <input type="checkbox"/> D		
	Connector socket AMP Junior-Timer <input type="checkbox"/> J		
	Connector Deutsch DT04-2P <input type="checkbox"/> G		
Sealing material	NBR <input type="checkbox"/>		
	FKM (Viton) <input type="checkbox"/> D1		
Manual override	Armature tube closed (standard) <input type="checkbox"/>		
	With screwed sealing plug <input type="checkbox"/> HB0		
	With manual emergency actuation <input type="checkbox"/> HB4.5		
Design-Index (Subject to change)			

\* Only available in conjunction with other nominal voltages and connection versions. (See data sheet 1.1-181)

**SYMBOLS**

simplified

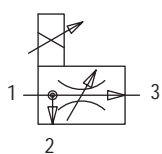

detailed

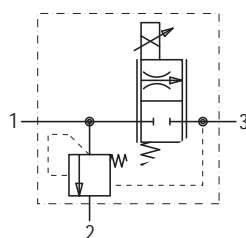
**GENERAL SPECIFICATIONS**

Description	3-way proportional flow control valve
Construction	Screw-in cartridge for cavity acc. to ISO 7789
Operation	Proportional solenoid
Mounting	Screw-in thread 1 <sup>5</sup> / <sub>16</sub> "-12 UN
Ambient temperature	-20...50 °C
Mounting position	any
Fastening torque	$M_D = 80 \text{ Nm}$ for screw-in cartridge $M_D = 7 \text{ Nm}$ for knurled nut
Weight	$m = 1,00 \text{ kg}$
Flow direction	see symbol

**ELECTRICAL SPECIFICATIONS**

Construction	Proportional solenoid, wet pin push type, pressure tight	
Standard nominal voltage	U = 12 VDC	U = 24 VDC
Limiting current	I <sub>G</sub> = 1560 mA	I <sub>G</sub> = 780 mA
Relative duty factor	100 % ED/DF (see data sheet 1.1-430)	
Protection class acc. to EN60529	Connection version D: IP65 J: IP66 G: IP67 and 69K	

For further electrical specifications see data sheet 1.1-180 (W)  
1.1-181 (M)

**HYDRAULIC SPECIFICATIONS**

Fluid	Mineral oil, other fluid on request
Contamination efficiency	ISO 4406:1999, class 18/16/13 (Required filtration grade $\beta_{6...10} \geq 75$ ) see data sheet 1.0-50/2
Viscosity range	12 mm <sup>2</sup> /s...320 mm <sup>2</sup> /s
Fluid temperature	-20...+70 °C
Peak pressure	p <sub>max</sub> = 350 bar
Nominal volume flow rates	Q <sub>N</sub> = 32 l/min, 63 l/min
Max. volume flow	Q <sub>max</sub> = 100 l/min (1 → 2)
Min. volume flow	Q <sub>min</sub> = 0,4 l/min
Hysteresis	≤ 5% * * at optimal dither signal

**CHARACTERISTICS** Oil viscosity  $\nu = 30 \text{ mm}^2/\text{s}$ 

Q = f (l) Volume flow adjustment characteristics 1 → 3 (p<sub>3</sub> = 100 bar)

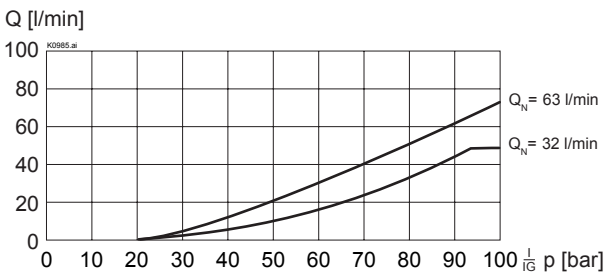

Q = f (p) Volume flow pressure characteristics (l = l<sub>G</sub>)

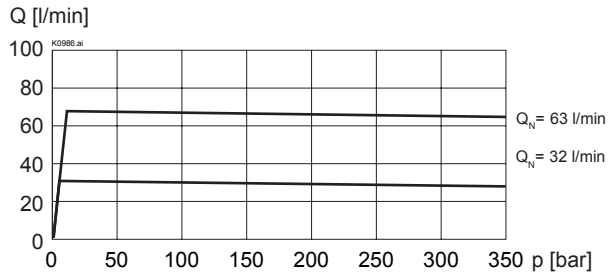

$\Delta p = f(Q)$  Pressure drop-volume flow characteristics 1 → 2 (l = 0 mA)

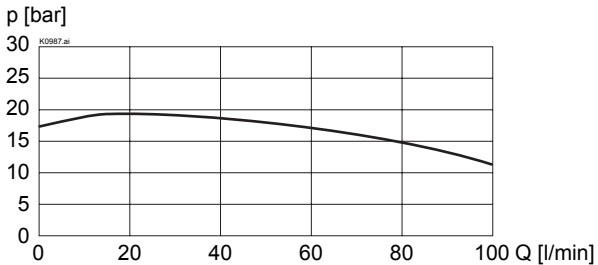

$\Delta p = f(Q)$  Pressure drop-volume flow characteristics 1 → 3 (l = l<sub>G</sub>)

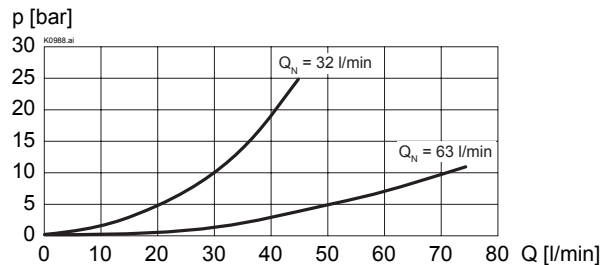

## DIMENSIONS / SECTIONAL DRAWINGS

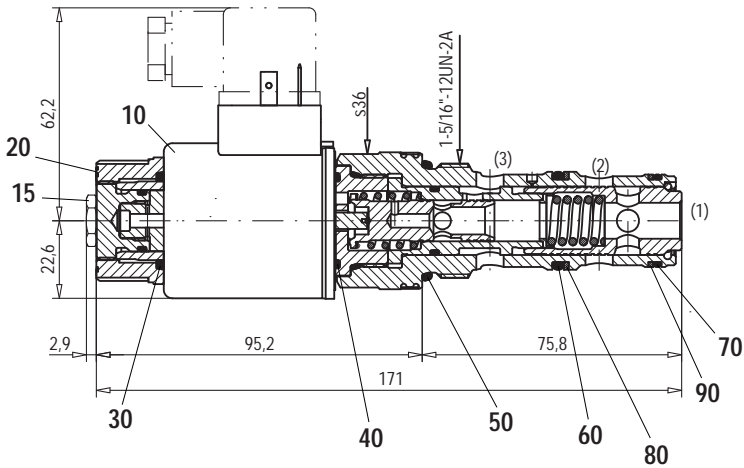

Cavity drawing acc. to Wandfluh standard

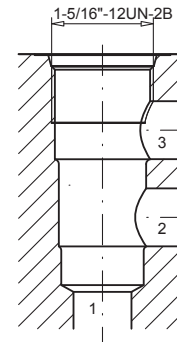

For detailed cavity drawing see data sheet 2.13-1046

## PARTS LIST

Position	Article	Description
10	206.1200	EN 175301 Solenoid coil WD45/23x50-G24
	206.1203	Solenoid coil WD45/23x50-G12
		Junior-Timer
	206.1201	Solenoid coil WJ45/23x50-G24
	206.1204	Solenoid coil WJ45/23x50-G12
		Deutsch
	206.1202	Solenoid coil WG45/23x50-G24
	206.1205	Solenoid coil WG45/23x50-G12
15	253.8000	HB 4,5 anual override (data sheet 1.1-300)
	239.2033	HB 0 Plug screw (data sheet 1.1-300)
20	154.2701	Knurled nut
30	160.6222	O-ring ID 22,22x2,62 (FKM)
40	160.6218	O-ring ID 21,95x1,78 (FKM)
50	160.2298	O-ring ID 29,82x2,62 (NBR)
	160.6296	O-ring ID 29,82x2,62 (FKM)
60	160.2238	O-ring ID 23,81x2,62 (NBR)
	160.6238	O-ring ID 23,81x2,62 (FKM)
70	160.2236	O-ring ID 23,52x1,78 (NBR)
	160.6236	O-ring ID 23,52x1,78 (FKM)
80	049.3297	Backup ring RD 24,5x29x1,4
	049.3276	Backup ring RD 24,1x27x1,4

## ACCESSORIES

 Proportional amplifier  
 Mating connector EN 175301-803

 Register 1.13  
 Article no. 219.2002

Technical explanation see data sheet 1.0-100