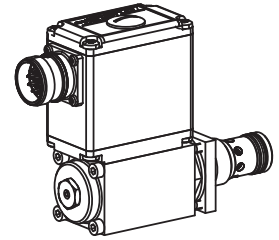

**Proportional 2-way flow control valve
Screw-in cartridge**

- Integrated electronics
- Direct operated, pressure compensated
- $Q_{max} = 25 \text{ l/min}$, $p_{max} = 350 \text{ bar}$
- $Q_{Nmax} = 25 \text{ l/min}$

M22x1,5
 ISO 7789

DESCRIPTION

Direct operated, pressure compensated proportional flow control valve with integrated electronics as a screw-in cartridge with a thread M22x1,5 for cavity acc. to ISO 7789. These plug & play valves are factory set and adjusted. High valve-to-valve reproducibility. Housing for electronics with protection class IP67 for harsh environment. The volume flow is adjusted by a Wandfluh proportional solenoid (VDE standard 0580). Almost linear flow increase and low hysteresis are typical for this valve. The cartridge body is made of steel. A special surface treatment guarantees a good protection against corrosion as well as very good low-friction characteristics of the pressure compensating- and throttle spool. The solenoid is zinc-coated.

FUNCTION

The 2-way flow control valve is designed to keep the oil flow to any actuator constant irrespective of the load. Proportionally to the command signal applied to the electronics spool stroke, metering opening and volume flow increase. The control connection is provided by an analog interface or a fieldbus interface (CANopen or Profibus DP). Parameter setting and diagnosis with the free-of-charge software «PASO» or via fieldbus interface. After taking off the cover of the electronics housing, the serial interface to adjust the settings is accessible. The menu controlled Windows program «PASO» allows easy adjustment of all variable settings. Data are stored in a non-volatile memory. Even after an electric power failure settings can easily be reproduced and transmitted.

APPLICATION

Proportional flow control valves are suitable for precise feed control system where the supply volume flow needs to be kept constant even when the load fluctuates. They are implemented in systems calling for good valve-to-valve reproducibility, easy installation, comfortable operation and high precision in industrial hydraulics as well as in mobile hydraulics. The screw-in cartridge is very suitable for mounting in control blocks, flange bodies and sandwich plates of the size NG4-mini and NG6. Cavity tools are available for machining cartridge cavities (hire or purchase). Please refer to the data sheets in register 2.13.

CONTENTS

GENERAL SPECIFICATIONS.....	1
SYMBOL.....	1
HYDRAULIC SPECIFICATIONS.....	2
ELECTRIC SPECIFICATIONS.....	2
START-UP.....	2
CONNECTOR WIRING DIAGRAM.....	2
CHARACTERISTICS.....	3
DIMENSIONS/ SECTIONAL DRAWINGS.....	3-4
PARTS LIST.....	4
ACCESSORIES (not included).....	4

TYPE CODE

	Q	N	V	PM22	-		-		#	
Flow control valve										
Normally closed										
Proportional valve with integrated electronics										
Screw-in cartridge M22x1,5										
Nominal volume flow rates Q_N :	3,2 l/min									
	8 l/min									
	18 l/min									
	25 l/min									
Standard nominal voltage U_N :	12 VDC									
	24 VDC									
Hardware configuration:										
With analog signal (0...+10 V factory set)										A1
With CANopen acc. to DSP-408										C1
With Profibus DP in accordance with Fluid Power Technology										P1
With CAN J1939 (on request)										J1
Design-Index (Subject to change)										

GENERAL SPECIFICATIONS

Description	2-way proportional flow control valve with integrated electronics
Construction	Screw-in cartridge for cavity acc. to ISO 7789
Operations	Proportional solenoid, wet pin push type, pressure tight
Mounting	Screw-in thread M33x2
Ambient temperature	-20...65 °C (typical) (The upper temperature limit is a guideline value for typical applications, in individual cases it may also be higher or lower. The electronics of the valve limit the power in case of a too high electronics temperature. More detailed information can be obtained from the operating instructions «DSV».)
Mounting position	any
Fastening torque	$M_D = 50 \text{ Nm}$ for screw-in cartridge $M_D = 2,8 \text{ Nm}$ (Qual. 8.8) for solenoid screws
Weight	$m = 0,95 \text{ kg}$
Flow direction	1 → 2

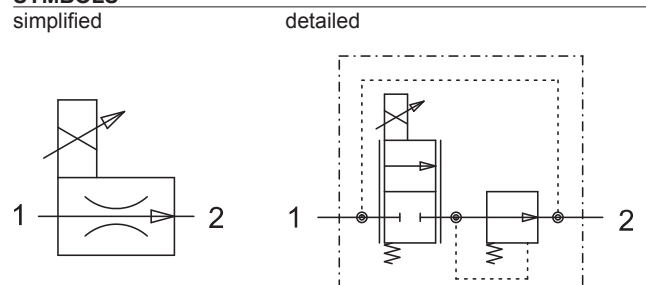
SYMBOLS

HYDRAULIC SPECIFICATIONS

Fluid	Mineral oil, other fluid on request
Contamination efficiency	ISO 4406:1999, class 18/16/13 (Required filtration grade $\beta_{6...10} \geq 75$) see data sheet 1.0-50/2
Viscosity range	12 mm ² /s...320 mm ² /s
Fluid temperature	-20...+70 °C
Peak pressure	$p_{max} = 350$ bar
Nominal volume flow rates	$Q_N = 32$ l/min, 63 l/min
Max. volume flow	$Q_{max} = 100$ l/min (1 → 2)
Min. volume flow	$Q_{min} = 0,2$ l/min
Leakage volume flow	see characteristics
Repeatability	≤ 2 %
Hysteresis	≤ 5 %

ELECTRICAL SPECIFICATIONS

Protection class	IP 67 acc. to EN 60 529 with suitable connector and closed electronic housing
Supply voltage	12 VDC or 24 VDC
Ramps	adjustable
Parameterisation	via fieldbus or USB
Interface	USB (Mini B) for parameterisation with «PASO» (under the closing screw of the housing cover, factory set parameters)

Analog interface:

Device receptacle (male)	M23, 12-poles
Mating connector	Plug (female), M23, 12-poles (not incl. in delivery)
Preset value signal	Voltage / Current

Fieldbus interface:

Device receptacle supply (male)	M12, 4-poles
Mating connector	Plug (female), M12, 4-poles (not incl. in delivery)
Device receptacle CANopen (male)	M12, 5-poles (acc. to DRP 303-1)
Mating connector	Plug (female), M12, 5-poles (not incl. in delivery)
Device receptacle Profibus (female)	M12, 5-poles, B-coded (acc. to IEC 947-5-2)
Mating connector	Plug (male), M12, 5-poles, B-coded (not incl. in delivery)
Preset value signal	Fieldbus

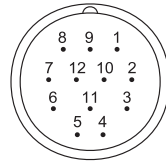

NOTE!
Detailed electrical characteristics and description of «DSV» electronics are shown on data sheet **1.13-75**.

CONNECTOR WIRING DIAGRAM
Analog interface:
Device receptacle (male) X1

- 1 = Supply voltage +
- 2 = Supply voltage 0 VDC
- 3 = Stabilised output voltage
- 4 = Preset value voltage +
- 5 = Preset value voltage -
- 6 = Preset value current +
- 7 = Preset value current -
- 8 = Reserved for extensions
- 9 = Reserved for extensions
- 10 = Enable control (Digital input)
- 11 = Error signal (Digital output)
- 12 = Chassis

Preset value voltage (PIN 4/5) resp. current (PIN 6/7) are selected with set-up and diagnosis software.
Factory setting: Voltage (0...+10 V), (PIN 4/5)

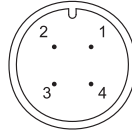
Fieldbus interface:
Device receptacle supply (male) X1

- MAIN**
- 1 = Supply voltage +
 - 2 = Reserved for extensions
 - 3 = Supply voltage 0 VDC
 - 4 = Chassis

Device receptacle CANopen (male) X3

- CAN**
- 1 = not connected
 - 2 = not connected
 - 3 = CAN Gnd
 - 4 = CAN High
 - 5 = CAN Low

Device receptacle Profibus (female) X3

- PROFIBUS**
- 1 = VP
 - 2 = RxD/TxD - N
 - 3 = DGND
 - 4 = RxD/TxD - P
 - 5 = Shield

Parameterisation interface (USB, Mini B) X2

Under the closing screw of the housing cover



NOTE!
The mating connectors and the cable to adjust the settings are not part of the delivery. To order the cable, look up the article no. in the chapter «Accessories».

START-UP

Normally there is no need to adjust settings by the customer. The connector has to be wired according to the chapter «Connector wiring diagram».

Additional information can be found on our website:
«www.wandfluh.com»

Free-of-charge download of the «PASO»-software and the instruction manual for the «DSV» hydraulic valves as well as the operation instruction **CANopen** protocol eg. **Profibus DP** protocol with device profile DSP-408 for «DSV»

CHARACTERISTICS Oil viscosity $\nu = 30\text{mm}^2/\text{s}$

$Q = f(I)$ Volume flow adjustment characteristics
 [at 50 bar difference of pressure]
 (s corresponds to preset value signal)

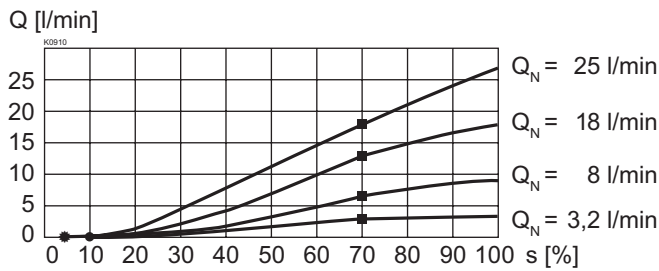

$Q = f(p)$ Volume flow pressure characteristics

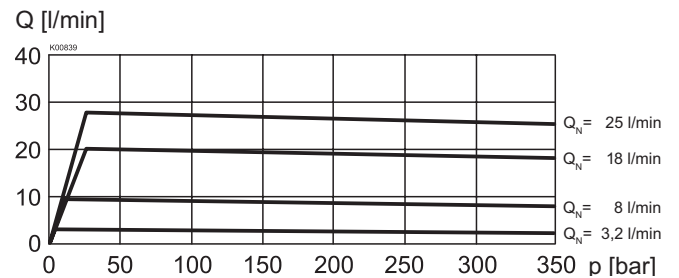
Factory settings:

Dither set for optimal hysteresis

- = Deadband: Solenoid switched off with command signal <5%
- = Beginning of control: at 10% of preset vale signal
- = Regulated volume flow at 70% of preset value signal
 18,0 l/min bei $Q_N = 25$ l/min
 13,2 l/min bei $Q_N = 18$ l/min
 6,7 l/min bei $Q_N = 8$ l/min
 2,6 l/min bei $Q_N = 3,2$ l/min

$Q_L = f(p)$ Leakage volume flow characteristics

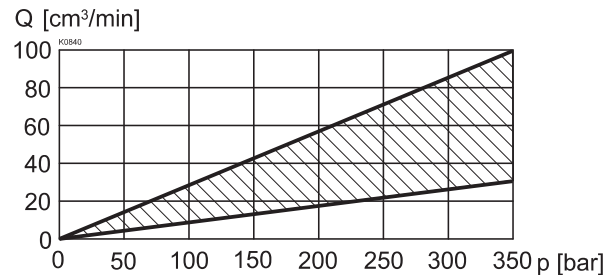

DIMENSIONS / SECTIONAL DRAWINGS

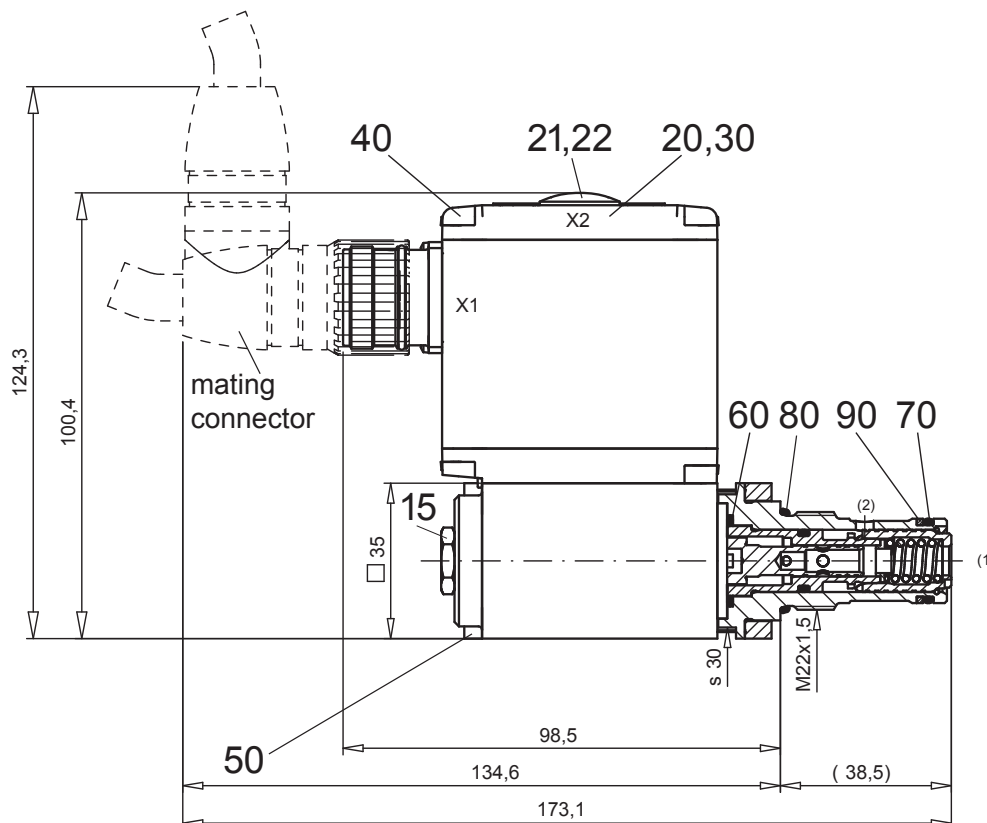
With analog interface

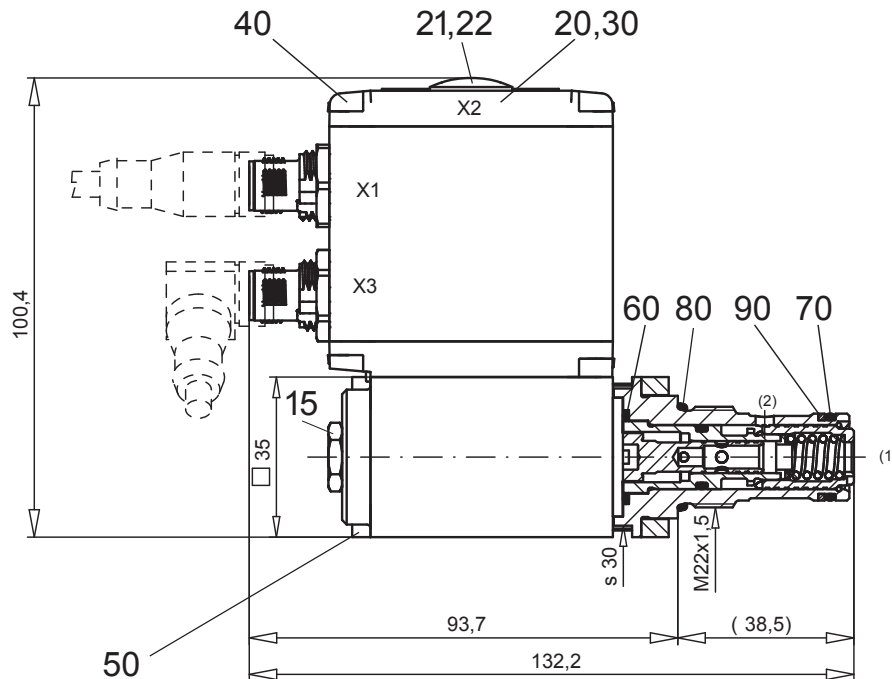
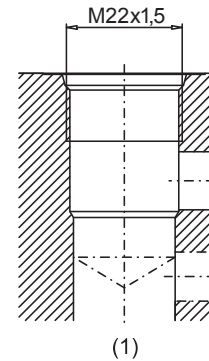

DIMENSIONS / SECTIONAL DRAWINGS

With fieldbus interface

 Cavity drawing acc. to
 ISO 7789-22-04-0-98

 For detailed cavity drawing
 and cavity tools see data
 sheet 2.13-1008

PARTS LIST

Position	Article	Description
15	253.8000	Mounted screw with integrated manual override HB4,5
20	062.0102	Cover square
21	223.1317	Dummy plug M16 x 1,5
22	160.6131	O-ring ID 13,00 x 1,5
30	072.0021	Gasket 33,2 x 59,9 x 2
40	208.0100	Socket head cap screw M4 x 10
50	246.1166	Socket head cap screw M4 x 65 DIN 912
60	160.2236	O-ring ID 15,60 x 1,78
70	160.2188	O-ring ID 18,77 x 1,78
80	160.2170	O-ring ID 17,17 x 1,78
90	049.3191	Back-up ring RD 24,1 x 27 x 1,4

ACCESSORIES

- Set-up software see start-up
 - Cable to adjust the settings through interface USB
 (from plug type A to Mini B, 3 m) article no. 219.2896
 - Cable connector for analog interface:
 - straight, soldering contact article no. 219.2330
 - 90°, soldering contact article no. 219.2331
- Recommended cable size:*
- Outer diameter 9...10,5 mm
 - Single wire max. 1 mm²
 - Recommended wire size:
 0...25 m = 0,75 mm² (AWG18)
 25...50 m = 1 mm² (AWG17)

Technical explanation see data sheet 1.0-100E

NOTE!

The cable connector is not part of the delivery. Regarding the dimensions see also the connector in the chapter «Accessories».