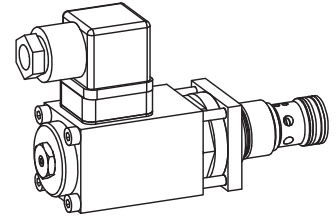

**Proportional throttle valve**
**Screw-in cartridge**

- Direct operated, not pressure compensated
- Throttle in one flow direction
- $Q_{\max} = 32 \text{ l/min}$ ,  $p_{\max} = 350 \text{ bar}$
- $Q_{N\max} = 25 \text{ l/min}$

**M22x1,5**  
 ISO 7789

**DESCRIPTION**

Direct operated proportional throttle valve. Thread M22x1,5 and cavity in accordance with ISO 7789. Spool options „normally closed“ and „normally open“. Three flow ranges are available. The volume flow is adjusted by a Wandfluh proportional solenoid (VDE standard 0580). Progressive increase and decrease of volume flow and reduced hysteresis are characteristics of this valve. The cartridge body is made of steel. Its special surface coating protects the outside against corrosion and reduces friction of the control spool. The solenoid is zinc coated.

**FUNCTION**

The force controlled wet pin proportional solenoid acts directly on the control spool which opens or closes the throttle segments of the radial holes in the valve body. The throttle opening and therefore the flow volume changes proportionally to the current input to the proportional solenoid. With deenergised solenoid, the control spool is held in closed respectively open position by a spring. To control the valve proportional amplifiers are available from Wandfluh (see register 1.13).

**APPLICATION**

Proportional throttle valves are suitable for precise feed control systems. Very sensitive opening and closing characteristics allow smooth control of movements in stationary or mobile installations, e.g. machine tools, public vehicles. The screw-in cartridge is suitable for installation in control blocks. Installation of the screw-in cartridge in control blocks as well as in the Wandfluh sandwich plates (vertical stacked systems) and flange valves of the NG4-Mini and NG6 types. (Please note the separate data sheets in register 2.6). Cavity tools are available for machining the cavities in steel and aluminium (hire or purchase). Please refer to the data sheets in register 2.13.

**CONTENT**

GENERAL SPECIFICATIONS.....	1
HYDRAULIC SPECIFICATIONS.....	1
ELECTRICAL SPECIFICATIONS.....	1
SYMBOLS.....	1
CHARACTERISTICS.....	2
DIMENSIONS/ SECTIONAL DRAWINGS.....	2
PARTS LIST.....	2
ACCESSORIES.....	2

**TYPE CODE**

		D	<input type="checkbox"/>	P	PM22 -	<input type="checkbox"/>	-	<input type="checkbox"/>	#	<input type="checkbox"/>
Throttle valve										
Normally closed	<input type="checkbox"/>	N								
Normally open	<input type="checkbox"/>	O								
Proportional										
Screw-in cartridge M22x1,5										
Nominal volume flow rates $Q_N$ :	6,3 l/min	<input type="checkbox"/>	6,3							
(at 10 bar pressure drop)	10 l/min	<input type="checkbox"/>	10							
	25 l/min	<input type="checkbox"/>	25							
Standard nominal voltage $U_N$ :	12 VDC	<input type="checkbox"/>	G12							
	24 VDC	<input type="checkbox"/>	G24							

Design-Index (Subject to change)

**GENERAL SPECIFICATIONS**

Description	Direct operated proportional throttle valve
Construction	Screw-in cavity acc. to ISO 7789
Operations	Proportional solenoid
Mounting	Screw-in thread M22x1,5
Ambient temperature	-20...50 °C
Mounting position	any
Fastening torque	$M_D = 50 \text{ Nm}$ for screw-in cartridge $M_D = 2,6 \text{ Nm}$ (Qual. 8.8) for solenoid screws
Weight	$m = 0,75 \text{ kg}$
Volume flow direction	1 → 2

**HYDRAULIC SPECIFICATIONS**

Fluid	Mineral oil, other fluid on request
Contamination efficiency	ISO 4406:1999, class 18/16/13 (Required filtration grade ( $\beta_{6...10} \geq 75$ ) (see data sheet 1.0-50)
Viscosity range	12 mm <sup>2</sup> /s...320 mm <sup>2</sup> /s
Fluid temperature	-20...+70 °C
Peak pressure	$p_{\max} = 350 \text{ bar}$
Nominal volume flow rates	$Q_N = 6,3 \text{ l/min}$ , 10 l/min, 25 l/min at 10 bar pressure drop
Max. Volume flow	$Q_{\max} = 32 \text{ l/min}$
Leakage volume flow	see characteristics
Resolution	1 mA
Hysteresis	≤ 5 % * * at optimal dithersignal

**ELECTRICAL SPECIFICATIONS**

Construction	Proportional solenoid, wet pin push type, pressure tight	
Standard nominal voltage	U = 12 VDC	U = 24 VDC
Limiting current	$I_G = 1250 \text{ mA}$	$I_G = 680 \text{ mA}$
Relative duty factor	100% DF (see data sheet 1.1-430)	
Protection class	IP 65 acc. to EN 60 529	
Connection/Power	Over device plug connection to supply ISO 4400 / DIN 43 650 (2P+E)	
Other electrical specifications	see data sheet 1.1-115 (PI35V)	

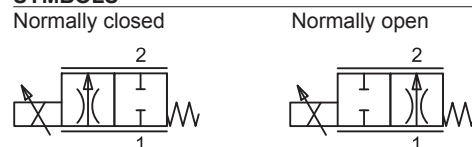
**SYMBOLS**

**CHARACTERISTICS** Oil viscosity  $\nu = 30 \text{ mm}^2/\text{s}$ 
**Q = f (p)** Volume flow pressure characteristics (DNPPM22)

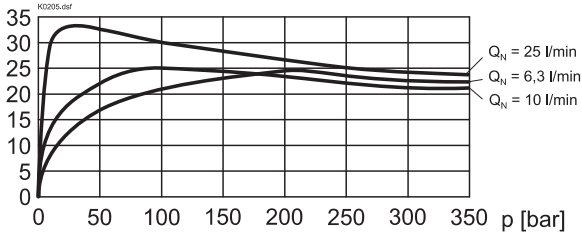
**Q [l/min]**

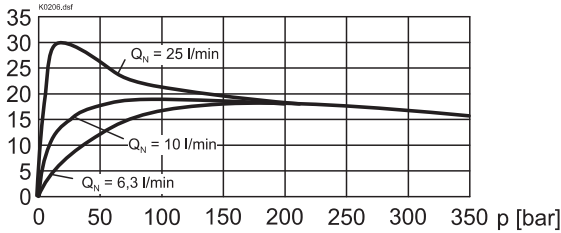
**Q = f (p)** Volume flow pressure characteristics (DOPPM22)

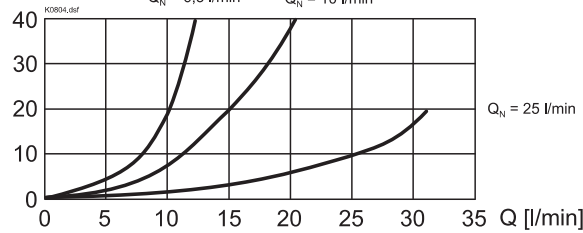
**Q [l/min]**

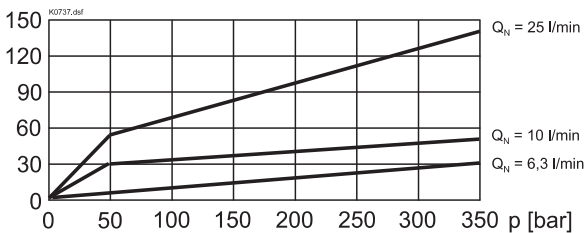
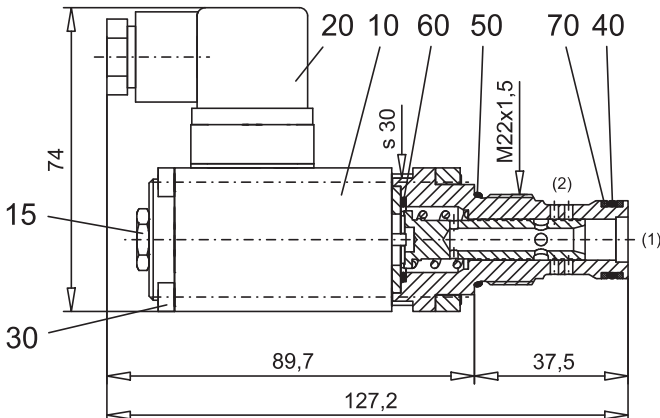
 **$\Delta p = f (Q)$**  Pressure drop volume flow characteristics (DNPPM22)

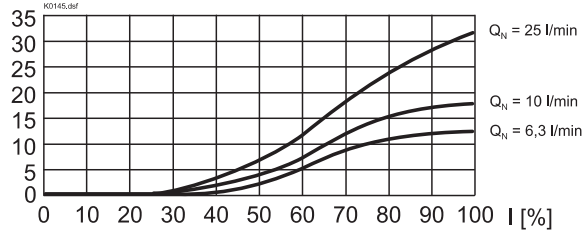
 **$\Delta p$  [bar]**

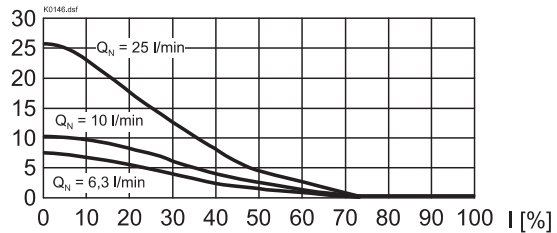
 **$Q_L = f (p)$**  Leakage volume flow characteristics

 **$Q_{L \text{ max}}$  [cm<sup>3</sup>/min]**

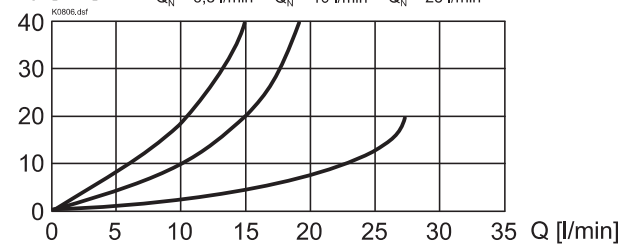
**DIMENSIONS / SECTIONAL DRAWINGS**

**Q = f (l)** Volume flow adjustment characteristics (DNPPM22)

**Q [l/min]**

**Q = f (l)** Volume flow adjustment characteristics (DOPPM22)

**Q [l/min]**

 **$\Delta p = f (Q)$**  Pressure drop volume flow characteristics (DOPPM22)

 **$\Delta p$  [bar]**

**PARTS LIST**

Position	Article	Description
10	256.3454 256.3426	Proportional solenoid PI35V-G24 Proportional solenoid PI35V-G12
15	253.8000	Mounted screw with integrated manual override HB4,5
20	219.2002	Plug (black)
30	246.1171	Socket head cap screw M4x70 DIN 912
40	160.2156	O-ring ID 15,60x1,78
50	160.2188	O-ring ID 18,77x1,78
60	160.2170	O-ring ID 17,17x1,78
70	049.3196	Back up ring RD 16,1x19x1,4

**ACCESSORIES**

Cartridge built-in flange- or sandwich body

Flange/Sandwichplate

Proportional amplifier

register 2.6

register 1.13

 Cavity drawing ISO 7789-22-01-0-98  
 and cavity tools see

data sheet 2.13-1008

Technical explanation see data sheet 1.0-100D