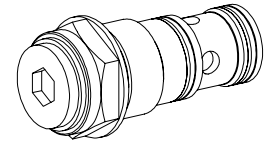

**Pressure compensating valve
Screw-in cartridge**

- 2- and 3-way operation
- $Q_{max} = 100 \text{ l/min}$
- $p_{max} = 350 \text{ bar}$

M33x2
 ISO 7789

DESCRIPTION

Pressure compensator valve with fixed settings, in screw cartridge construction with M33x2 thread for cavity acc. to ISO 7789. The valve is available in a 2 or 3 way design. The one-piece cartridge is made of steel. The external parts are zinc coated and therefore protected against rust.

FUNCTION

The pressure compensator valve keeps the pressure difference between inlet pressure at port P and the pressure in output port A or B on the directional valve nearly constant. It ensures that, for a given actuating spool position, a precise amount of oil, which is not dependent on load pressure, flows through the directional valve. Pressure compensating valves are mostly used in conjunction with proportional valves.

APPLICATION

2-way pressure compensating valve: Volume flow changes resulting from pressure or load changes in the consumer are corrected. Cylinder or motor speeds remain constant. If several consumers are operating in parallel, the full system pressure is available to each one.

3-way pressure compensating valve: Surplus output flow is cost-effectively led to the return system. This prevents the hydraulic system from overheating, especially in mobile systems which lack the necessary cooling surfaces. Parallel operation is not possible. If there are several consumers the pump pressure is set at the maximum working pressure.

Important: Pressure compensators are only suitable for open loop control.

CONTENTS

GENERAL SPECIFICATIONS	1
HYDRAULIC SPECIFICATIONS	1
SYMBOLS	1
MECHANICAL ACTUATION	1
CHARACTERISTICS	2
DIMENSIONS	2
PARTS LIST	2
ACCESSORIES	2

TYPE CODE

		U	F	PM33	#	
Pressure compensator, 2-way operation	Z					
Pressure compensator, 3-way operation	D					
Types of adjustment: fixed setting						
M33x2 screw cartridge						
Design-Index (Subject to change)						

GENERAL CHARACTERISTICS

Designation	2- and 3-way pressure compensating valve
Construction	Screw cartridge for cavity acc. to ISO 7789
Type of fastening	M33x2 screw thread
Ambient temperature	-20...+50°C
Installation position	any
Tightening torque	$M_D = 80 \text{ Nm}$
Weight:	$m = 0,52 \text{ kg}$ (2-way operation) $m = 0,42 \text{ kg}$ (3-way operation)

HYDRAULIC CHARACTERISTICS

Hydraulic fluid	mineral oils, other media on request
Max. permissible contamination level	ISO 4406:1999, class 18/16/13 (Recommended filter gauge $\beta_{6...10} \geq 75$) see also data sheet 1.0-50/2
Viscosity range	12 mm ² /s...320 mm ² /s
Hydraulic fluid temp.	-20...+70°C
Peak pressure	$p_{max} = 350 \text{ bar}$
Differential pressure	$p_{Diff.} = 10 \text{ bar}$ other differential pressures on request
Max. volume flow	$Q_{max} = 100 \text{ l/min}$
Leakage volume flow	see curve

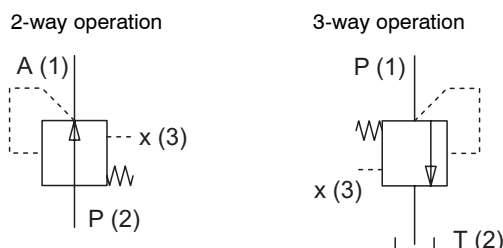
SYMBOLS

MECHANICAL ACTUATION

Fixed setting design. Other differential pressure available on request.

PERFORMANCE CHARACTERISTICS Oil viscosity $\nu = 30 \text{ mm}^2/\text{s}$

2-way operation

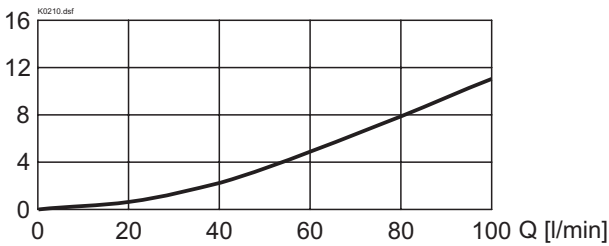
 $\Delta p = f(Q)$ Pressure drop-volume flow curve

 Δp [bar]

3-way operation

 $\Delta p = f(Q)$ Pressure drop-volume flow curve

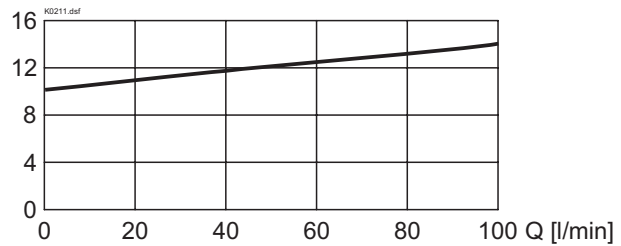
 Δp [bar]

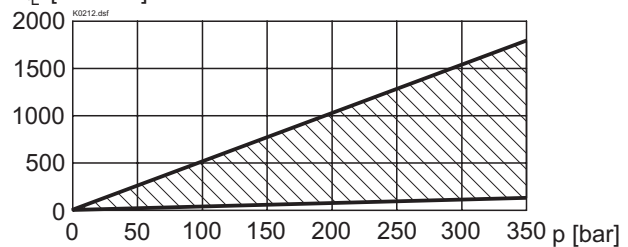
 $Q_L = f(p)$ Leakage volume flow curve

 Q_L [cm³/min]

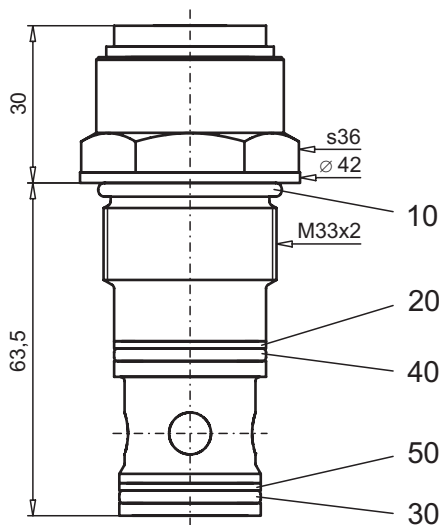
DIMENSIONS

2-way operation

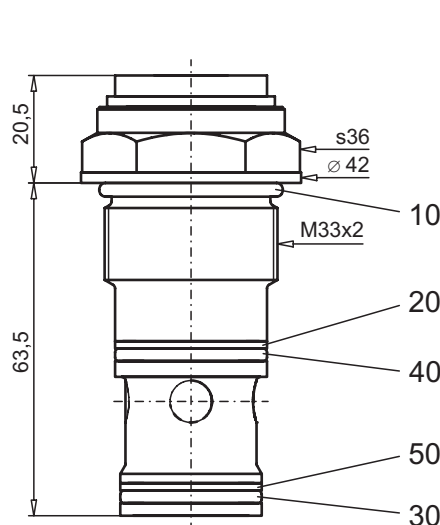

3-way operation



Cavity drawing according to ISO 7789-33-06-0-98

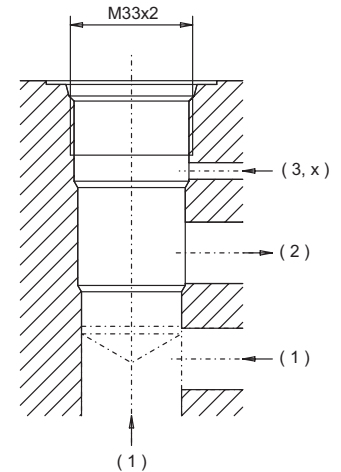

For detailed cavity drawings and cavity tools see data sheet 2.13-1011.

PARTS LIST

Position	Article	Description
10	160.2298	O-ring ID 29,82x2,62
20	160.2252	O-ring ID 25,12x1,78
30	160.2236	O-ring ID 23,52x1,78
40	49.3296	Back-up ring RD 26,1x29x1,4
50	49.3276	Back-up ring RD 24,1x27x1,4

ACCESSORIES

Cartridge installed in sandwich plates:

Sandwich valve

register 2.5

Technical explanation see data sheet 1.0-100E