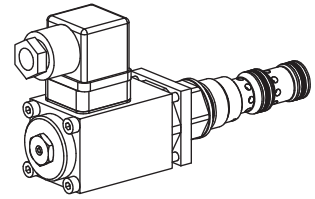

**Proportional pressure reducing valve
Screw-in cartridge**

- Pilot operated
- $Q_{max} = 60$ l/min
- $p_{max} = 400$ bar
- $p_{N\ red\ max} = 350$ bar

M22x1,5
 ISO 7789

DESCRIPTION

Pilot operated proportional pressure reducing valve as a screw-in cartridge with a thread M22x1,5 for cavity according to ISO 7789. Seven standard pressure levels are available. Adjustment by a Wandfluh proportional solenoid (VDE standard 0580). The cartridge and the solenoid made of steel are zinc coated and therefore rust-protected.

FUNCTION

The proportional pressure regulating valve controls the pressure in port A (1). Proportionally to the solenoid current solenoid force and pressure in port A (1) rise. The valve functions practically independently of pressure in port P (2). A pressure rise in Port A (1) above the set pressure e.g. due to an active oil consumer, will be prevented by relieving excess volume flow to tank via port T (3). With deneergised solenoid the volume flow passes freely from port P to the consumer port A. Design specific a minimum adjustable pressure according characteristic curve cannot be underpassed. To control the valve proportional amplifiers are available from Wandfluh (see register 1.13).

APPLICATION

The valve has its application in hydraulic systems, in which the pressure frequently has to be changed. The facility for remote control and signal processing from process control systems enable elegant, comfortable solutions to problems. Installation of the screw-in cartridge in control blocks as well as in the Wandfluh sandwich plates (vertical stacked systems) and flange valves of the NG4-Mini, NG6 and NG10 types. (Please note the separate data sheets in register 2.3). Cavity tools are available for machining the cavities in steel and aluminium (hire or purchase). Please refer to the data sheets in register 2.13.

CONTENT

GENERAL SPECIFICATIONS	1
HYDRAULIC SPECIFICATIONS	1
ELECTRICAL SPECIFICATIONS	1
SYMBOL	1
CHARACTERISTICS	2
DIMENSIONS/ SECTIONAL DRAWINGS	2
PARTS LIST	2
ACCESSORIES	2

TYPE CODE

Pressure reducing valve	M	V	P	PM22	-	[]	-	[]	#	[]
Pilot operated										
Proportional										
Screw-in thread M22x1,5										
Standard nominal pressure range $p_{N\ red}$:	20 bar	[20]	200 bar	[200]						
	63 bar	[63]	250 bar	[250]						
	100 bar	[100]	350 bar	[350]						
	160 bar	[160]								
Standard nominal voltage:	$U_N = 12$ VDC	[G12]								
	$U_N = 24$ VDC	[G24]								
Design-Index (Subject to change)										

• Data sheet is valid from design-index #2 on

GENERAL SPECIFICATIONS

Denomination	Pilot operated proportional pressure reducing valve
Construction	Screw-in cartridge for cavity acc. to ISO 7789
Operation	Proportional solenoid
Mounting	Screw in thread M22x1,5
Ambient temperature	-20...+50° C
Mounting position	any
Fastening torque	$M_D = 50$ Nm for screw-in cartridge $M_D = 2,6$ Nm (qual. 8.8) for solenoid screws
Weight	$m = 0,6$ kg

ELECTRICAL SPECIFICATIONS

Construction	Proportional solenoid, wet pin push type, pressure tight.	
Standard nominal voltage	$U_N = 12$ VDC	$U_N = 24$ VDC
Limiting current	$I_G = 1250$ mA	$I_G = 680$ mA
Relative duty factor	100% DF (see date sheet 1.1-430)	
Protection class	IP 65 acc. to EN 60 529	
Connection/Power supply	Over device plug connection to EN175301-803 (DIN43650) ISO4400, form A, (2P+E), other connections on request.	
Other electrical specifications	see data sheet 1.1-115 (PI35MV)	

HYDRAULIC SPECIFICATIONS

Fluid	Mineral oil, other fluid on request
Contamination efficiency	ISO 4406:1999, class 18/16/13 (Required filtration grade $\beta_{6...10} \geq 75$) refer to data sheet 1.0-50/2
Viscosity range	12 mm ² /s...320 mm ² /s
Fluid temperature	-20...+70° C
Peak pressure	$p_{max} = 400$ bar
Nominal pressure range:	$p_{N\ red} = 20$ bar, 63 bar, 100 bar, 160 bar, 200 bar, 250 bar, 350 bar
Volume flow range	$Q = 0...60$ l/min
Pilot- and leakage volume flow	see characteristics
Repeatability	$\leq 1\%$ *
Hysteresis	$\leq 4\%$ *
	* at optimal dither signal

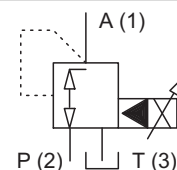
SYMBOL

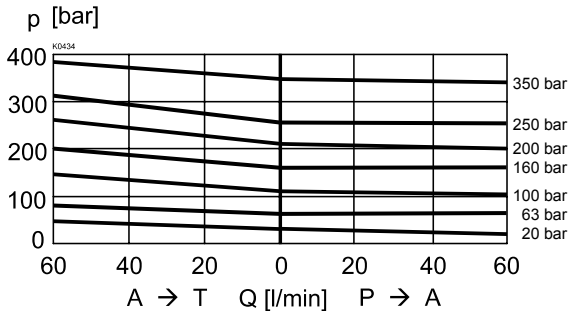
CHARACTERISTICS oil viscosity $\nu = 30 \text{ mm}^2/\text{s}$
 $p_{\text{red}} = f(Q)$ Pressure volume flow characteristics
 (Maximal adjustable pressure)

 $p_{\text{red}} = f(Q)$ Pressure volume flow characteristics
 (Minimal adjustable pressure)

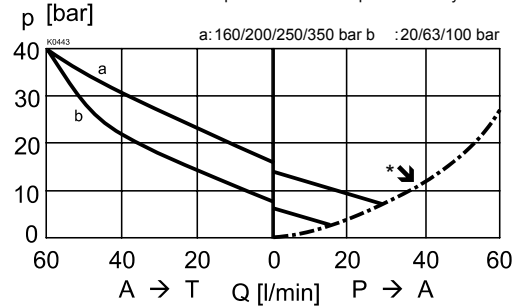
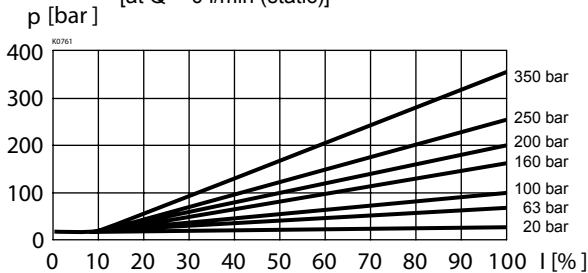
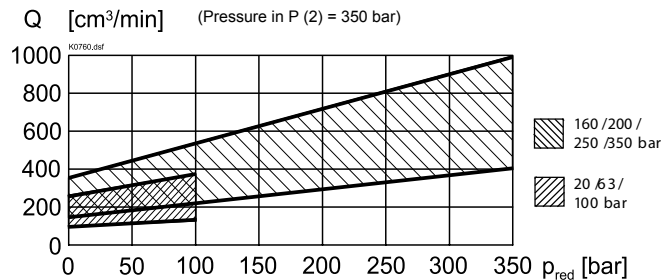
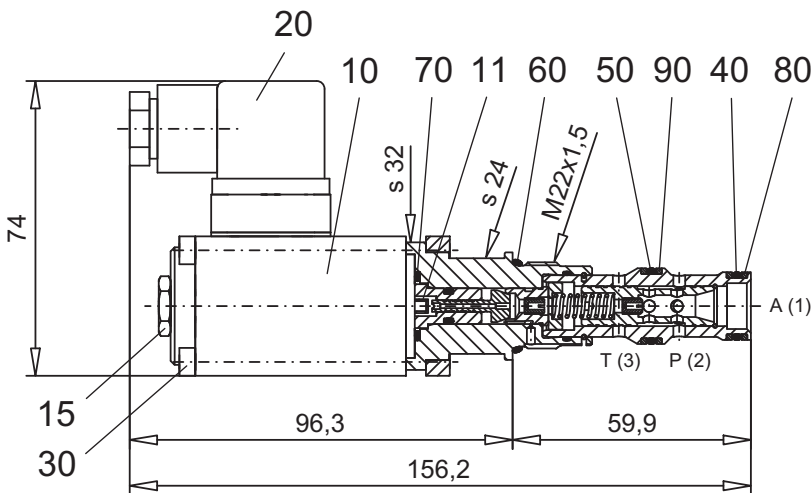
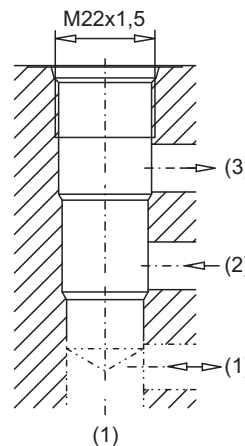
* Consumption resistance dependent on system

 $p_{\text{red}} = f(I)$ Pressure adjustment characteristics
 [at $Q = 0 \text{ l/min}$ (static)]

 $Q_{\text{st+L}} = f(p_{\text{red}})$ Pilot- and leakage volume flow characteristic [A(1) → T(3)]

DIMENSIONS / SECTIONAL DRAWINGS

 Cavity drawing acc. to
 ISO 7789-22-04-0-98

PARTS LIST

Position	Article	Description
10	256.3505 256.3443	Proportional solenoid PI35MV-G24 Proportional solenoid PI35MV-G12
11	034.0116	Pin RD 4x8
15	253.8000	Mounted screw with integrated manual override HB4,5
20	219.2002	Plug (black)
30	249.1007	Socket head cap screw M4x63
40	160.2140	O-ring ID 14,00x1,78
50	160.2156	O-ring ID 15,60x1,78
60	160.2188	O-ring ID 18,77x1,78
70	160.2140	O-ring ID 14,00x1,78
80	049.3176	Back-up ring RD 14,1x17x1,4
90	049.3196	Back-up ring RD 16,1x19x1,4

 For detailed cavity drawing
 and cavity tools see data
 sheet 2.13-1004

ACCESSORIES

 Cartridge built-in flange- or sandwich body
 Flange body / sandwich plate
 Proportional amplifier

 register 2.3
 register 1.13

Technical explanation see data sheet 1.0-100E