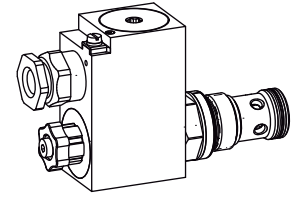

Poppet valve cartridges
2/2-way versions

- Pilot operated
- $Q_{max} = 120 \text{ l/min}$
- $p_{max} = 350 \text{ bar}$

M33x2
 ISO 7789

II 2 G Ex d II C
II 2 D Ex tD A21 IP65

DESCRIPTION

Pilot operated 2/2-way solenoid poppet valve in screw-in cartridge design with thread M33x2 for cavity acc. to ISO 7789.

Activated with Wandfluh explosion proof solenoid.

The solenoid spool is zinc-/nickel-coated. Solenoid coil in accordance with directive 94/9/EG (ATEX) for explosion-hazard zones.

Ex: In accordance with European standards EN 60079-0, EN 60079-1 (gas) EN 61241-0, EN 61241-1 (dust)

d: Pressure-proof encapsulation

tD: Protection by the housing

Device group II: For all explosion-hazard zones, except for underground workings

Gas group IIC: Gas groups IIA + IIB included

Device category 2G: For zones 1 and 2 (gas)

Device category 2D: For zones 21 and 22 (dust)

Zones: 1/21 and 2/22

EC-type test certification:

PTB 07 ATEX 1023

FUNCTION

For the function «normally closed» with deenergised pull-type solenoid, and «normally open» with energised push-type solenoid, the differential area poppet piston is held in closed position by a spring and seals leak free from port 2 to 1. If pull-type solenoid is energised respectively push-type solenoid deenergised, the poppet piston will open flow passage from 2 to 1 after having reached the opening pressure. In the «normally closed» valve with deenergised solenoid respectively the «normally open» valve with energised solenoid flow passage from 1 to 2 is open when the opening pressure has been reached.

APPLICATION

Wandfluh solenoid operated poppet valves are applied where an absolutely leak free closing of the valve is essential like in load holding-, clamping- or gripping functions. These valves are suitable for hazardous areas in off-shore and shipbuilding applications as well as in the chemical-, oil- and gas industry. The screw-in cartridges are mainly used in mobile or station-ary integrated blocks and in size NG10 flange and sandwich bodies. Cavity tools are available for machining cartridge cavities (hire or purchase). Please refer to the data sheets in register 2.13.

INSTALLATION

Tightening torque of the coil fixing nut MD = 15Nm. For stack assembly please observe the remarks in the operating instructions.

DESIGNATION

Execution L15:

II 2 G Ex d IIC T4

 $T_a = -25...70^\circ\text{C}$

II 2 D Ex tD A21 IP65 T130°C

Execution L9:

II 2 G Ex d IIC T6

 $T_a = -25...40^\circ\text{C}$

II 2 D Ex tD A21 IP65 T80°C

II 2 G Ex d IIC T4

 $T_a = -25...90^\circ\text{C}$

II 2 D Ex tD A21 IP65 T130°C

TYPE CODE

 S V Y PM33 - - - #

Poppet valve

Pilot operated

Explosion proof solenoid EEx d

Screw-in cartridge M33x2

Designation see symbols

 Standard-nominal voltage U_N :

12 VDC	<input type="checkbox"/>
24 VDC	<input type="checkbox"/>
115 VAC	<input type="checkbox"/>
230 VAC	<input type="checkbox"/>

 Nominal power P_N :

15 W	<input type="checkbox"/>	Ambient temp by:
9 W	<input type="checkbox"/>	70°C
		40°C or 90°C (only for CD+AB)

Design-Index (Subject to change)

GENERAL SPECIFICATIONS

Description	Pilot operated 2/2-way solenoid poppet valve
Construction	Screw-in cartridge for cavity acc. to ISO 7789
Operation	Solenoid
Mounting	Screw-in thread M33x2
Admissible ambient temperature	Execution L15: -20...+70°C (operation as T1...T4/T130°C) Execution L9: -20...+40°C (operation as T1...T6/T80°C) -20...+90°C (operation as T1...T4/T130°C) In case of $U_N < 20\text{V}$, the max. ambient temperature has to be reduced by 10°C.
Mounting position	any, preverable horizontal
Fastening torque	$M_D = 80 \text{ Nm}$ for cartridge $M_{D,max} = 5 \text{ Nm}$ for coil retaining nut
Weight	$m = 2,45 \text{ kg}$
Volume flow	see symbols

HYDRAULIC SPECIFICATIONS

Fluid	Mineral oil, other fluid on request
Contamination efficiency	ISO 4406:1999, class 18/16/13 Required filtration grade $\beta_{6...10} \geq 75$ (see data sheet 1.0-50/2)
Viscosity range	12 mm ² /s...320 mm ² /s
Admissible fluid temperature	Execution L15: -20...+70°C (operation as T1...T4/T130°C) Execution L9: -20...+40°C (operation as T1...T6/T80°C) -20...+70°C (operation as T1...T4/T130°C)
Working pressure	$p_{max} = 350 \text{ bar}$
Nominal volume flow	$Q_N = 100 \text{ l/min}$
Max. volume flow	$Q_{max} = 120 \text{ l/min}$
Pressure drop	$\Delta p_{max} < 10 \text{ bar}$ with 100 l/min
Opening pressure:	
Version CD/DC	2 → 1 = 2 bar / 1 → 2 = 1 bar
Version AB/BA	2 → 1 = 6 bar / 1 → 2 = 4 bar

SYMBOLS

SVYPM33 - DC...

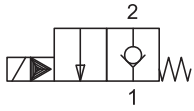

SVYPM33 - CD...

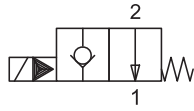

SVYPM33 - BA...

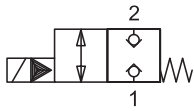

SVYPM33 - AB...

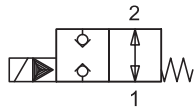
ELECTRICAL CONTROL

Construction	Switching solenoid, wet pin pull- or push type, pressure tight
Standard-nominal voltage	$U_N = 12 \text{ VDC}$, $U_N = 24 \text{ VDC}$ $U_N = 115 \text{ VAC}$, $U_N = 230 \text{ VAC}$ DC wired with VDR AC = 50 to 60 Hz $\pm 2\%$; with integrated two way rectifier and recovery diode
Voltage tolerance	$\pm 10\%$ of nominal voltage
Protection class	IP 65 acc. to EN 60529
Relative duty cycle	100% DF
Switching cycles	5000/h
Operating life	10^7 (number of switching cycles, theoretically)
Connection/Power supply	Through cable entry for cable diameter $\varnothing 11 \dots 14 \text{ mm}$ (acc. to EN 60079-0)
Temperature class	
Execution L15:	T1...T4
Execution L9:	T1...T6
Nominal power	
Execution L15:	15W
Execution L9:	9W

For further electrical characteristics, refer to the data sheet of the solenoid coil: 1.1-183

START-UP

Information concerning the installation and commissioning is contained in the operating instructions supplied together with the solenoid coil.

CHARACTERISTICS Oil viscosity $\nu = 30 \text{ mm}^2/\text{s}$

$p = f(Q)$ Performance limits with standard voltage -10%
 (measured at 50 °C)

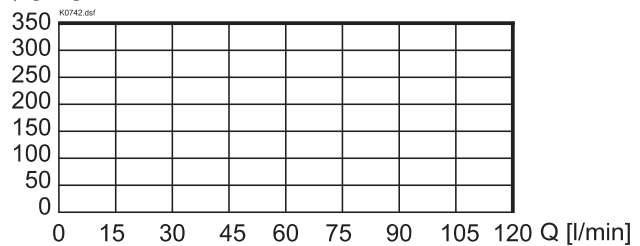

$\Delta p = f(Q)$ Pressure drop volume flow characteristics [DC/CD]

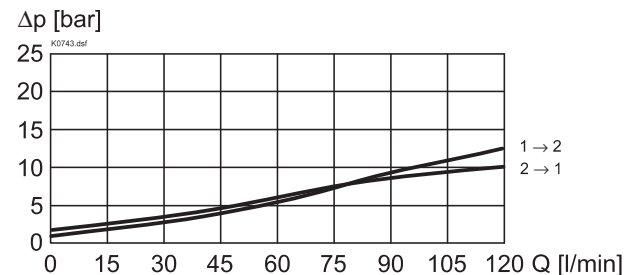

$\Delta p = f(Q)$ Pressure volume flow characteristics [BA/AB]

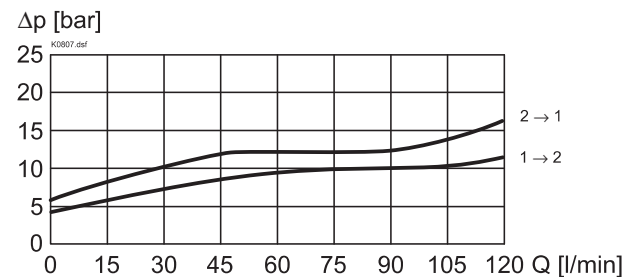
CAVITY

Cavity drawing to
 ISO 7789-33-01-0-98

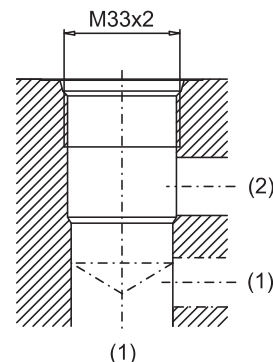

For detailed cavity drawing and cavity tools see data sheet 2.13-1005

DIMENSIONS/SECTIONAL DRAWING

2/2-way version, «normally closed» [DC]

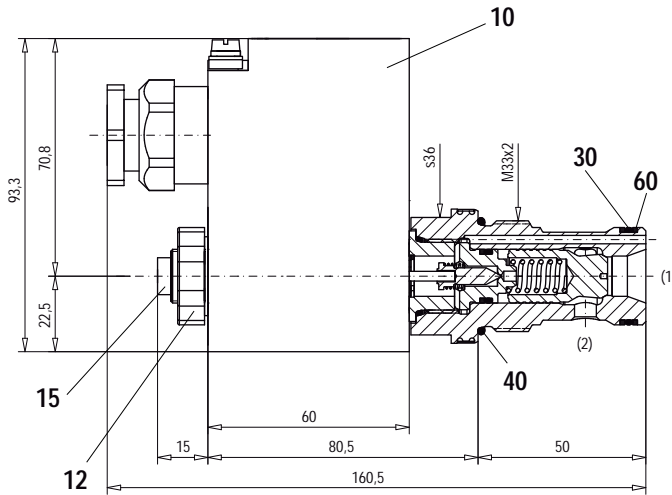

2/2-way version, «normally closed» [BA]

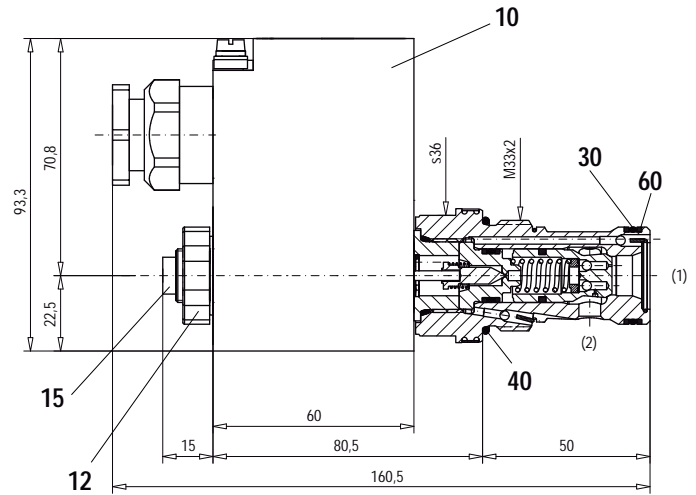

2/2-way version, «normally open» [CD]

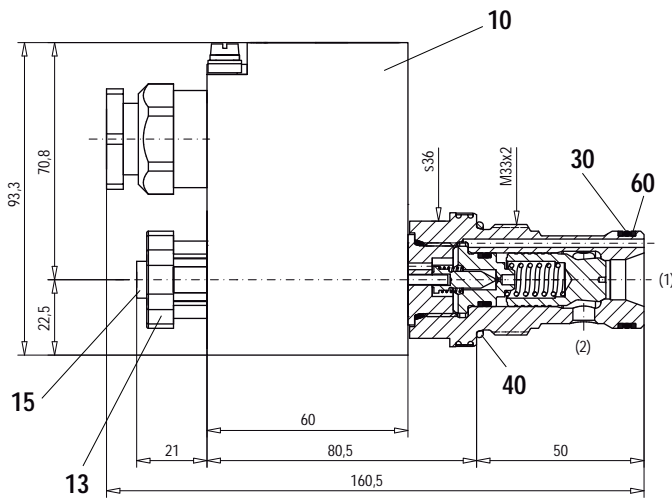

2/2-way version, «normally open» [AB]

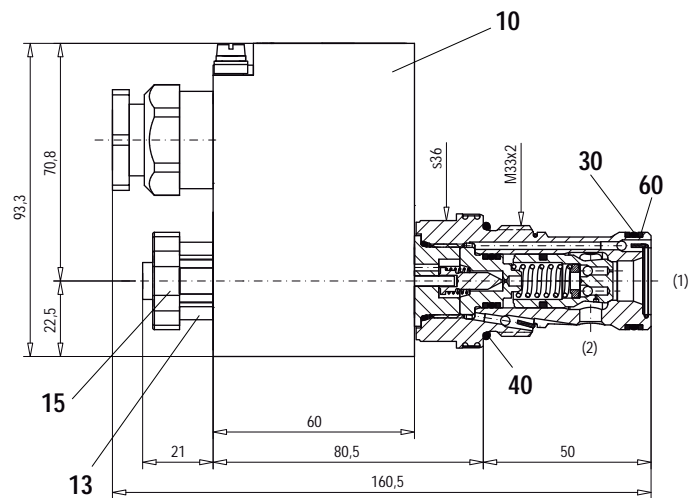
PARTS LIST

Position	Article	Description
10	263.6...	Coil type MKY 45/18x60...
12	154.2600	Knurled nut M16x1x9
13	154.2601	Knurled nut M16x1x18
15	239.2033	Plug HB0 (incl. seal)
30	160.2252	O-ring ID 25,12x1,78
40	160.2298	O-ring ID 29,82x2,62
60	049.3296	Back-up ring RD 26,1x29x1,4

ACCESSORIES

Cartridge built-in in flange- or sandwich body:

 Flange valve
 Sandwich valve

 register 1.11
 register 1.11

Technical explanation see data sheet

1.0-100